

Version history

Version 1.0	Initial Release
-------------	-----------------

Net	MST6X99GL PIN name	
ON_USB1	PIN196:GPIO[0]	
OTG_HOST_DET	PIN184:INT	
OTG_OC_DET	PIN191:GPIOB[0]	
ON_USB2	PIN238:GPIOE[3]	
USB2_OC_DET	PIN192:GPIOB[1]	
HDCEC	PIN129:GPIOC[0]	
AMP-MUTE	PIN200:DI[2]	
SDA_EXT	PIN104:SDA	
SCL_EXT	PIN105:SCL	
LED	PIN203:DI[4]	
PW_CTL	PIN205:DI[6]	
WP_EEP	PIN199:DI[1]	
WP_KEY	PIN198:DI[0]	
ON_FBACK	PIN204:DI[5]	
ON_PANEL	PIN206:DI[7]	
HP_DET	PIN201:DI[3]	
AU-SW0	PIN45:GPIOL[4]	
AU-SW1	PIN197:ICLK	
HD-SW0	PIN43:GPIOL[2]	
SIF_SW	PIN44:GPIOL[3]	
TXD1	PIN42:GPIOL[1]	
RXD1	PIN41:GPIOL[0]	
HDMI-PC0	PIN241:GPIOE[0]	
HDMI_SW2/SCL	PIN240:GPIOE[1]	
HDMI_SW1/SDA	PIN239:GPIOE[2]	

获取更多资料

微信搜公众号星球



获取更多资料 微信搜公众号 全球

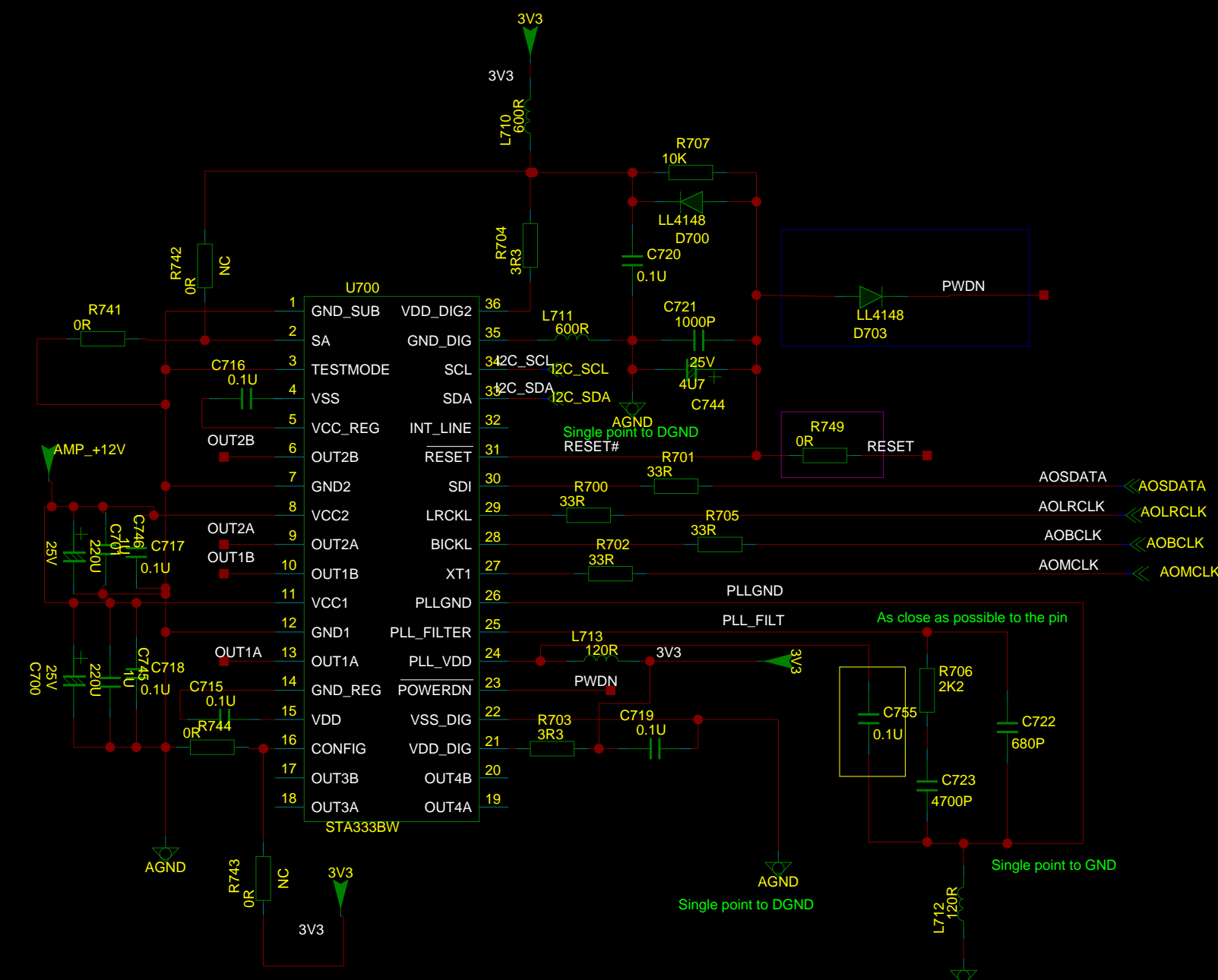

headphone circuit

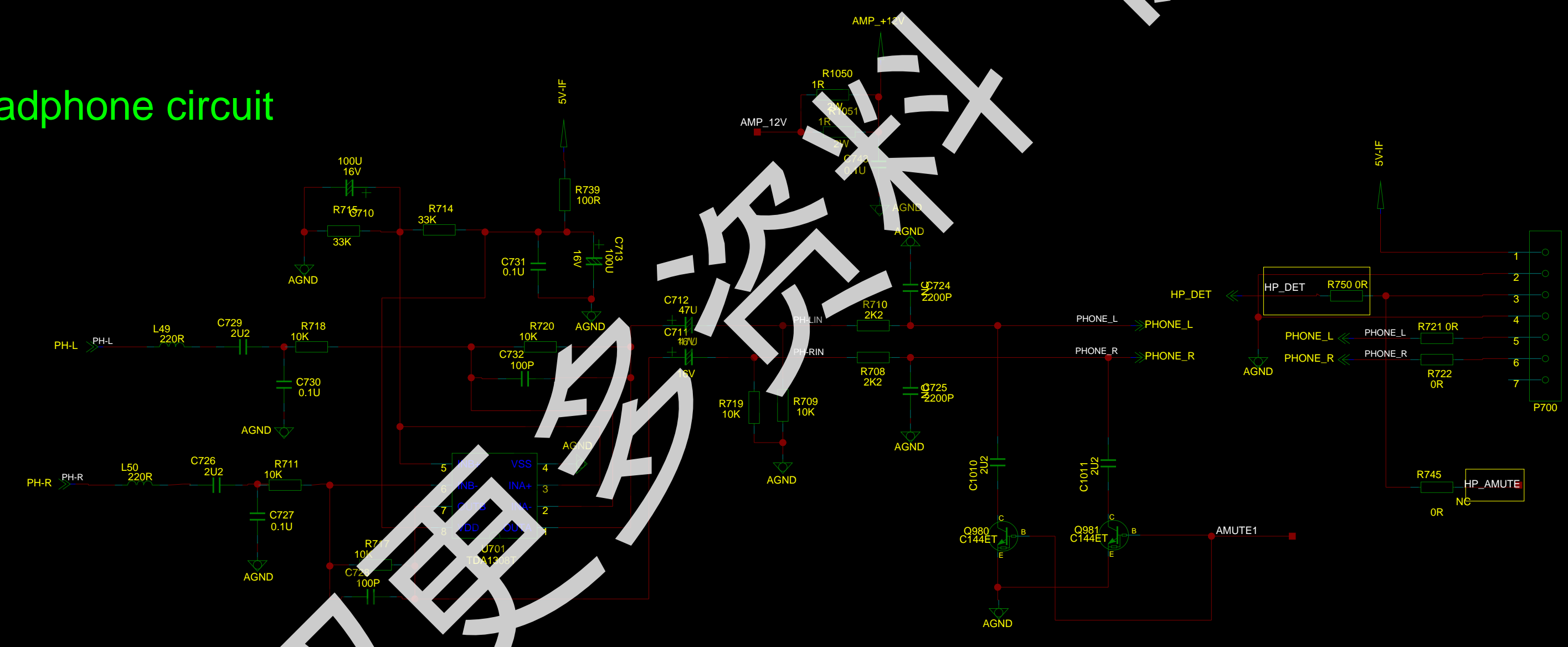

loudspeaker circuit

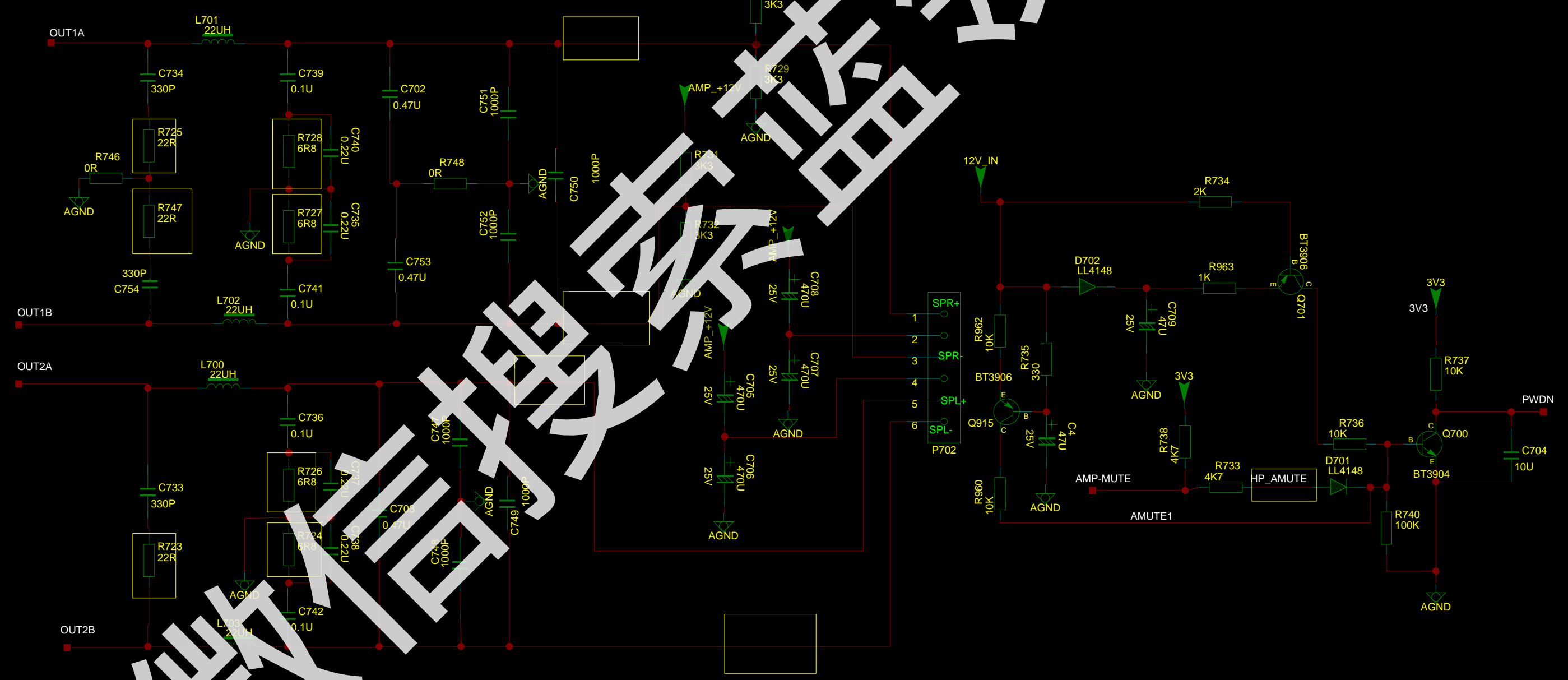

获取更多资料
 微信搜索 蓝蓝星球

...	DD-MM	SBU :
...	DD-MM	TCLNO:
...	DD-MM
...	DD-MM	DESIGNATION
Index-Lab	DATE	NAME	DESCRIPTION	Last modif
Last saved : 5-5-2008_16:29					

DRAWN	CHECKED	PAGE:
ON:	ON: DD-MM-YY	OF :
BY:	BY:	

TTE
 TCL Thomson Electronics Ltd.
 B Building, TCL Tower, Nanhai Road
 Nanshan District, Shenzhen, Guangdong
 Tel +86-755-3331xxxx Fax +86-755-3331xxxx

THIS DRAWING CANNOT BE COMMUNICATED TO UNAUTHORIZED PERSONS COPIED UNLESS PERMITTED IN WRITING

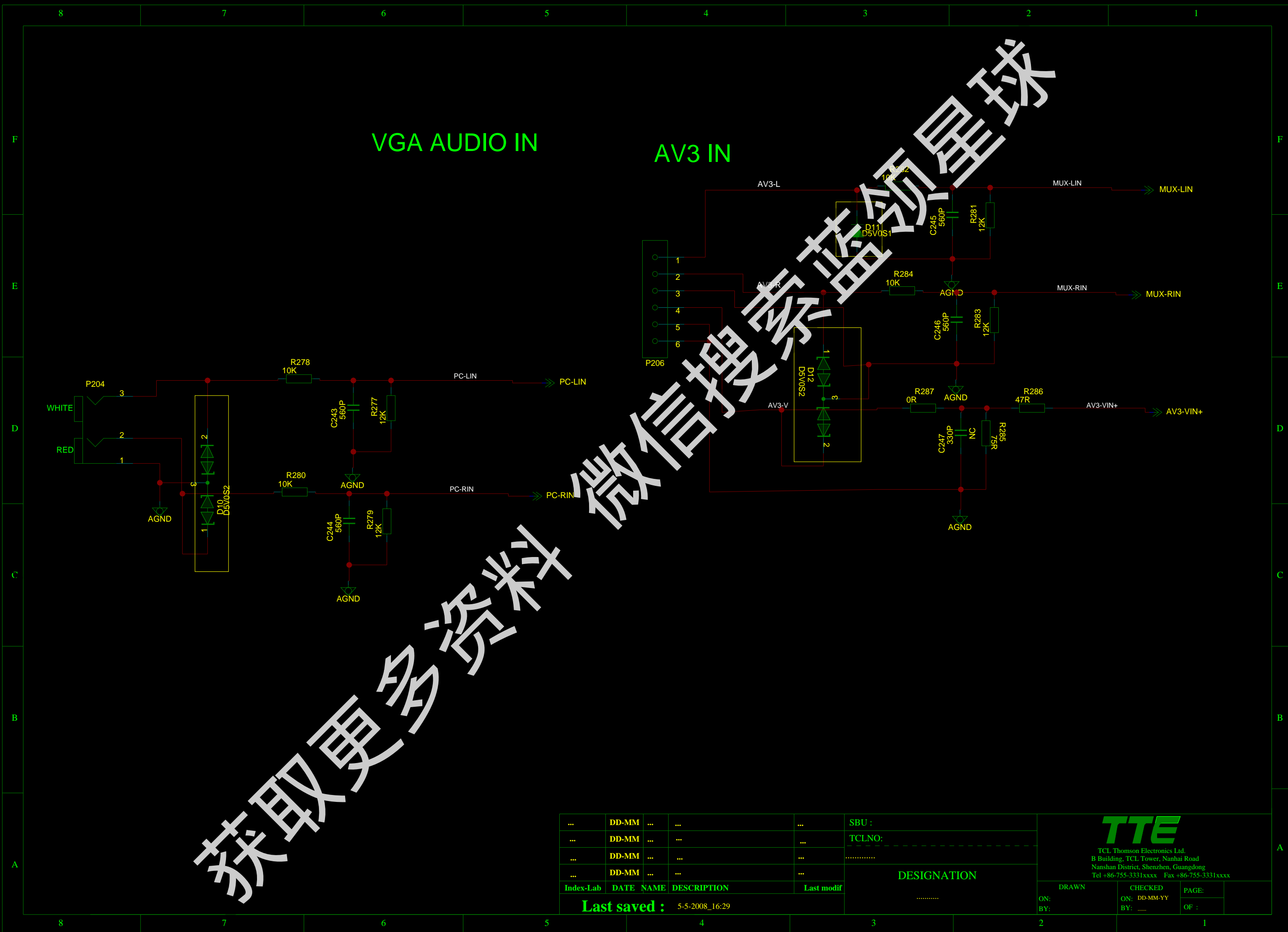

获取更多资料 微信搜索 蓝点星球

...	DD-MM	SBU :
...	DD-MM	TCLNO:
...	DD-MM
...	DD-MM	DESIGNATION
Index-Lab	DATE	NAME	DESCRIPTION	Last modif
Last saved : 5-5-2008_16:29					

DESIGNATION
.....

TTE		
TCL Thomson Electronics Ltd. B Building, TCL Tower, Nanhai Road Nanshan District, Shenzhen, Guangdong Tel +86-755-3331xxxx Fax +86-755-3331xxxx		
DRAWN	CHECKED	PAGE:
ON:	ON: DD-MM-YY	OF :
BY:	BY:	

THIS DRAWING CANNOT BE COMMUNICATED TO UNAUTHORIZED PERSONS COPIED UNLESS PERMITTED IN WRITING

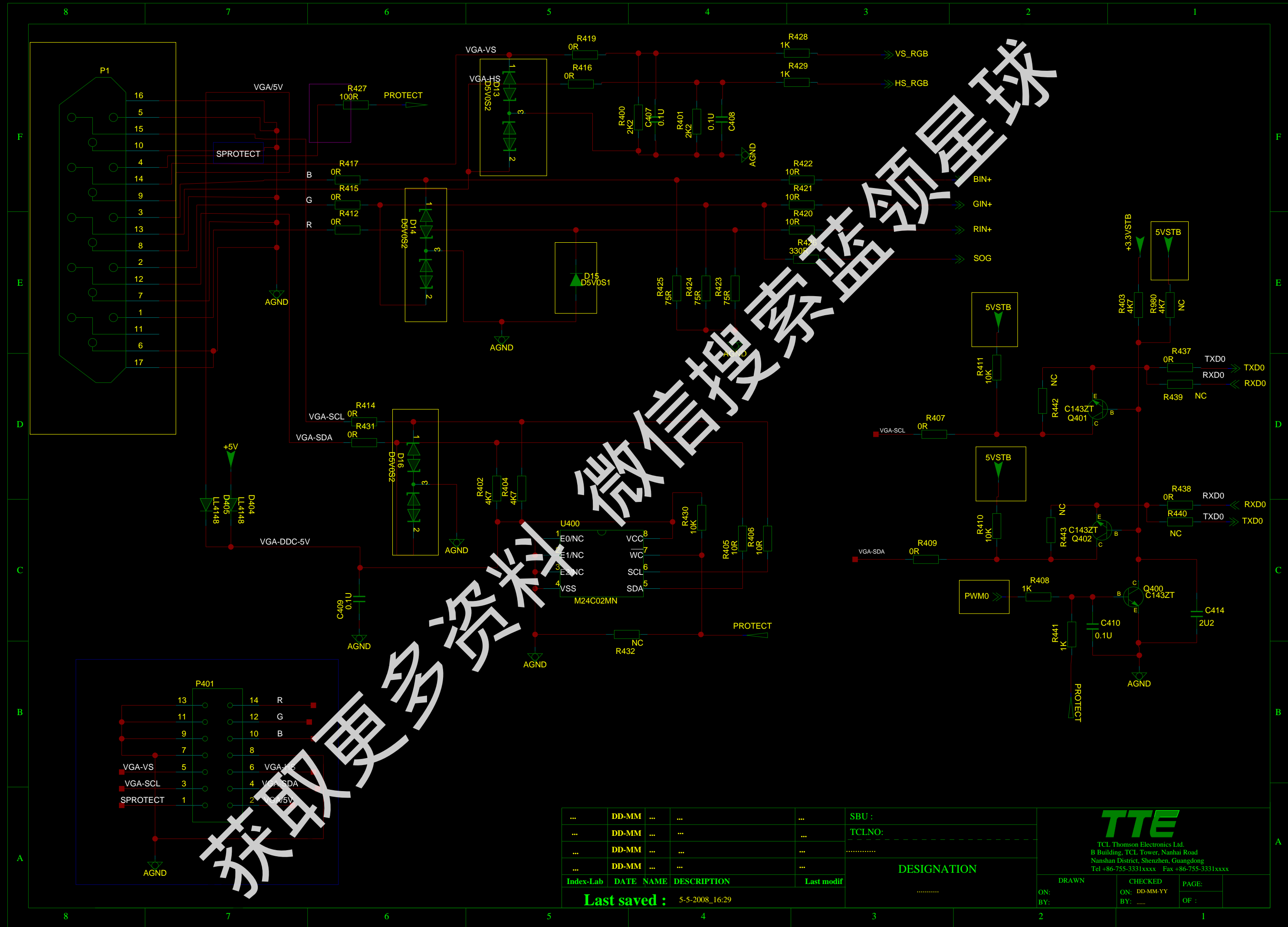

获取更多资料 微信搜索 蓝盾星球

...	DD-MM	SBU :
...	DD-MM	TCLNO:
...	DD-MM
...	DD-MM	DESIGNATION
Index-Lab	DATE	NAME	DESCRIPTION	Last modif
Last saved : 5-5-2008_16:29					

TTE
 TCL Thomson Electronics Ltd.
 B Building, TCL Tower, Nanhai Road
 Nanshan District, Shenzhen, Guangdong
 Tel +86-755-3331xxxx Fax +86-755-3331xxxx

DRAWN	CHECKED	PAGE:	
ON:	ON: DD-MM-YY	OF :	
BY:	BY:		

THIS DRAWING CANNOT BE COMMUNICATED TO UNAUTHORIZED PERSONS COPIED UNLESS PERMITTED IN WRITING

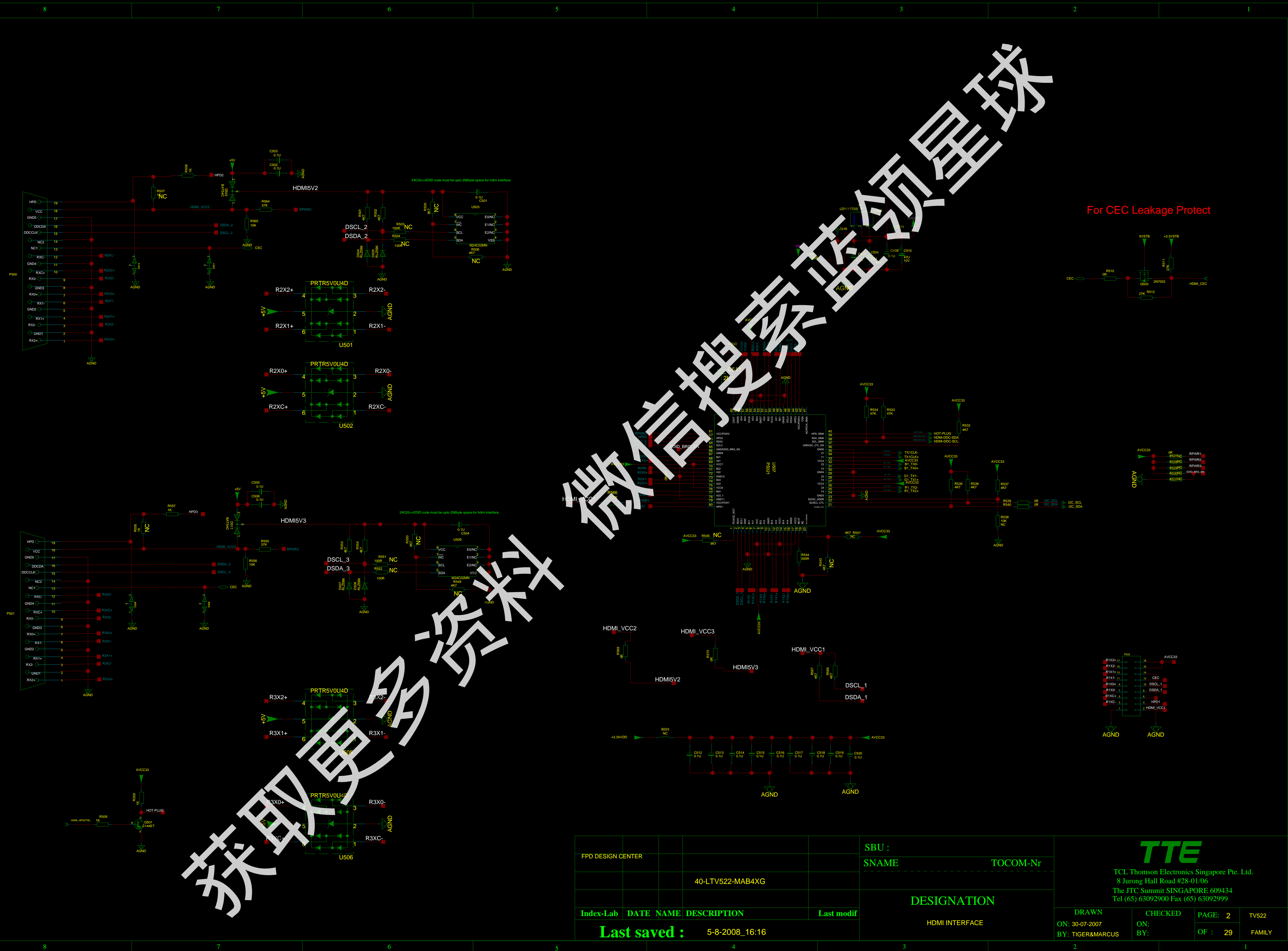

For CEC Leakage Protect

FPD DESIGN CENTER		SBU : SNAME		TOCOM-Nr	
40-LTV522-MAB4XG		DESIGNATION			
Index-Lab		DATE	NAME	DESCRIPTION	Last modif
Last saved :		5-8-2008_16:16			
DRAWN ON: 30-07-2007 BY: TIGER&MARCUS		CHECKED ON: BY:		PAGE: 2 OF : 29	TV522 FAMILY



TCL Thomson Electronics Singapore Pte. Ltd.
8 Jurong Hall Road #28-01/06
The JTC Summit SINGAPORE 609434
Tel (65) 63092900 Fax (65) 63092999

禁取更料

微电子技术全球

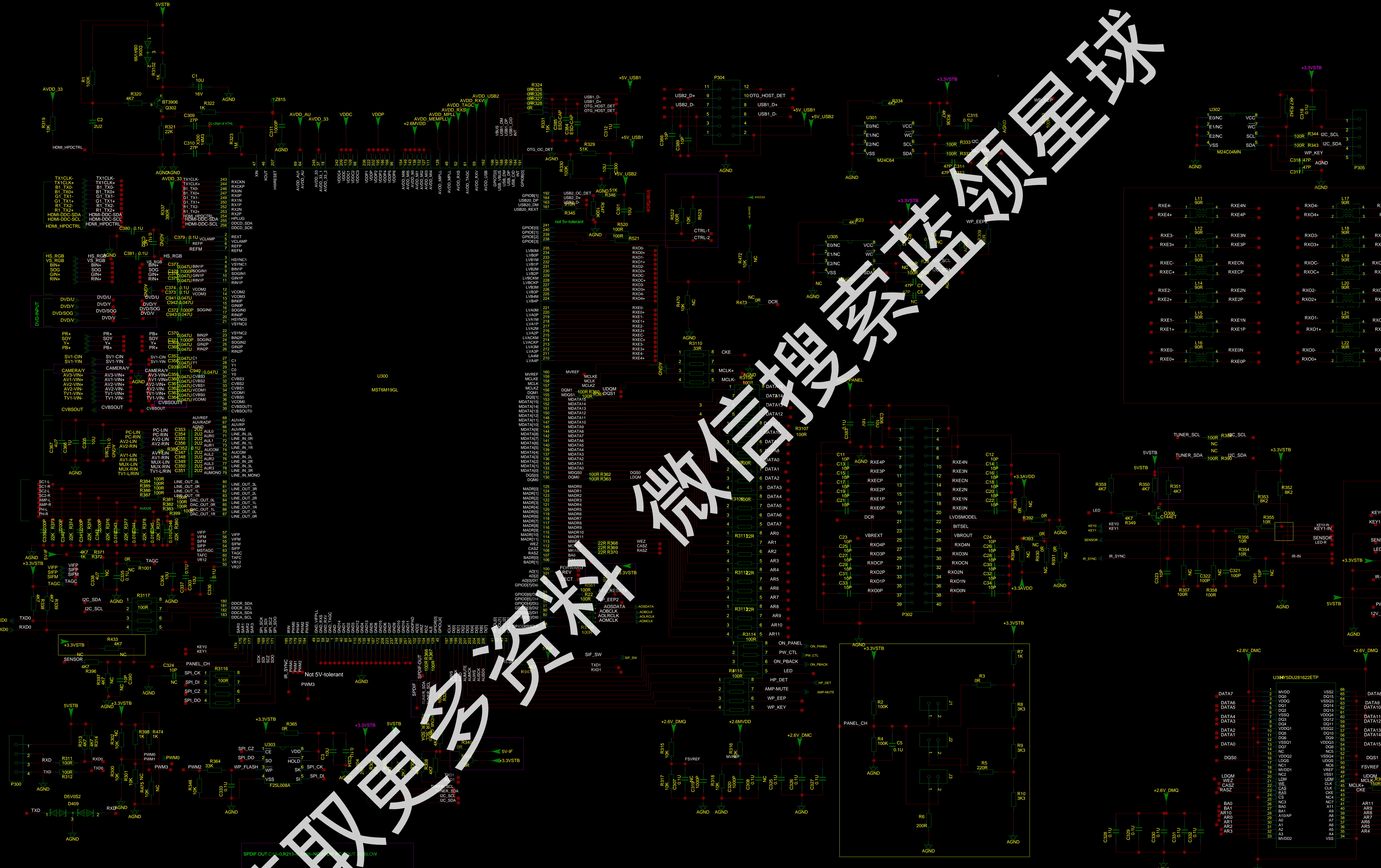

Index-Lab	DATE	NAME	DESCRIPTION	Last modif	SBU :	TCLNO:	DESIGNATION
...	DD-MM
...	DD-MM
...	DD-MM
...	DD-MM

Last saved : 5-5-2008_16:29

TTE

TCL Thomson Electronics Ltd.
B Building, TCL Tower, Nanhai Road
Nanshan District, Shenzhen, Guangdong
Tel +86-755-3331xxxx Fax +86-755-3331xxxx

DRAWN	CHECKED	PAGE:
ON:	ON: DD-MM-YY	OF :
BY:	BY:	

THIS DRAWING CANNOT BE COMMUNICATED TO UNAUTHORIZED PERSONS COPIED UNLESS PERMITTED IN WRITING

THIS DRAWING CANNOT BE COMMUNICATED TO UNAUTHORIZED PERSONS COPIED UNLESS PERMITTED IN WRITING

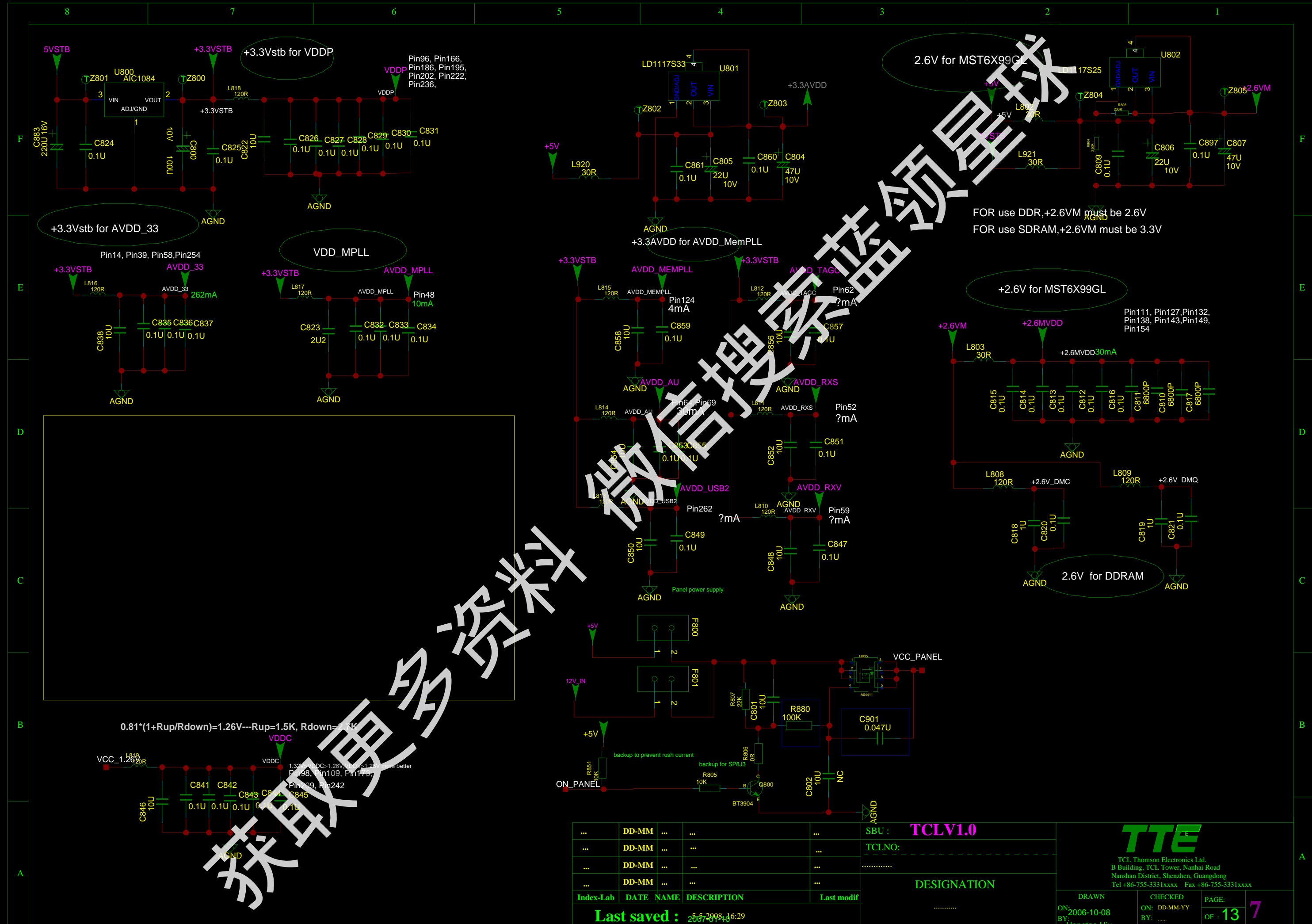

$0.81 \cdot (1 + R_{up}/R_{down}) = 1.26V$ --- $R_{up} = 1.5K$, $R_{down} = 10K$
1.32V VDDC > 1.26V VDDC > 1.28V VDDC is better
Pin98, Pin109, Pin113, Pin209, Pin242

FOR use DDR,+2.6VM must be 2.6V
FOR use SDRAM,+2.6VM must be 3.3V

+2.6V for MST6X99GL

2.6V for DDRAM

...	DD-MM	SBU : TCLV1.0
...	DD-MM	TCLNO:
...	DD-MM
...	DD-MM	DESIGNATION
Index-Lab	DATE	NAME	DESCRIPTION	Last modif

Last saved : 2007-09-10 16:29



TCL Thomson Electronics Ltd.
B Building, TCL Tower, Nanhai Road
Nanshan District, Shenzhen, Guangdong
Tel +86-755-3331xxxx Fax +86-755-3331xxxx

DRAWN	CHECKED	PAGE:
ON: 2006-10-08	ON: DD-MM-YY	OF: 13
BY: Hengtao Hui	BY:	

8.4 POWER SUPPLY & CMOS CONTROL & INVERTER



FOR DVD-COMB OR PVR

for camera

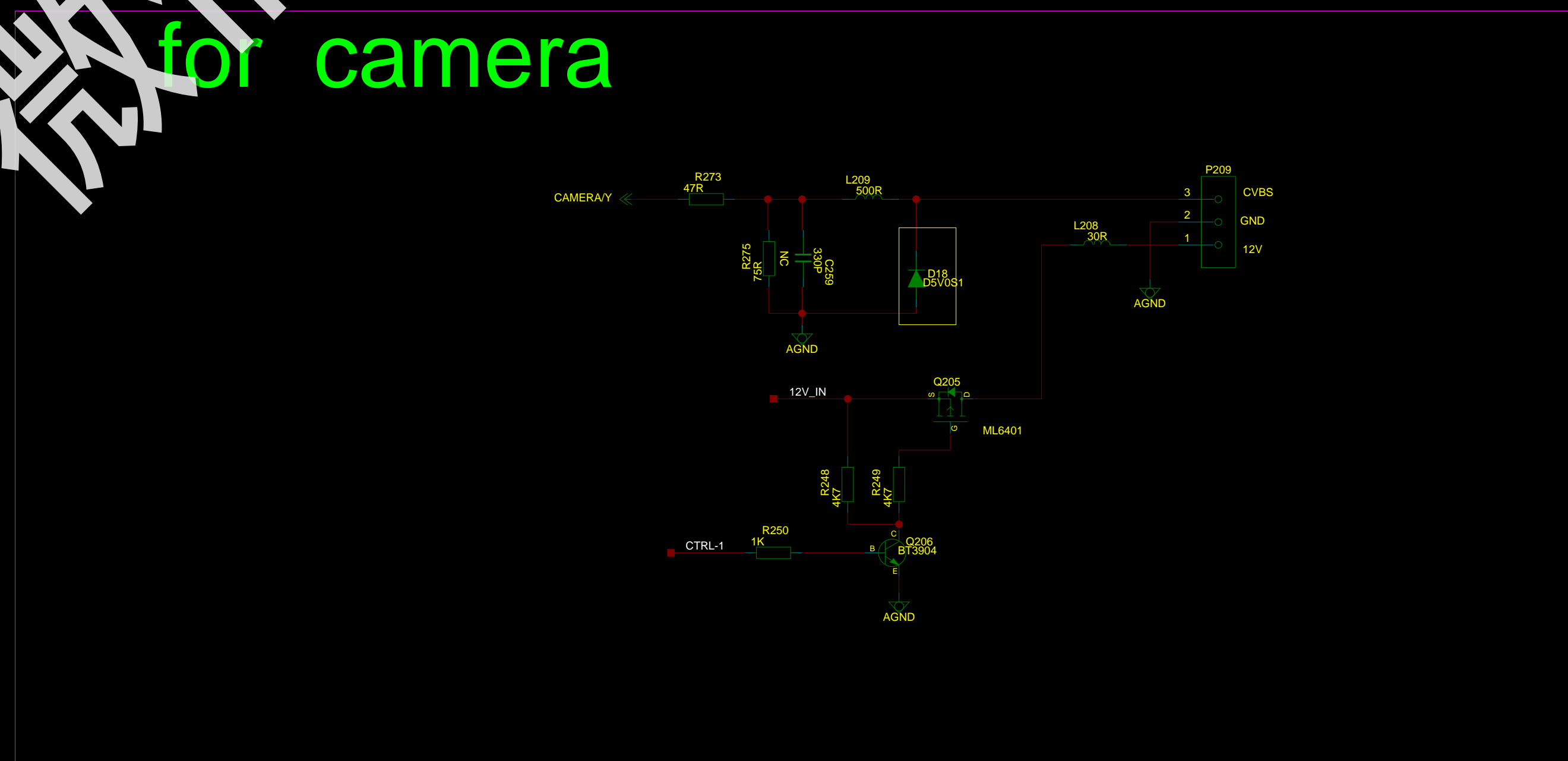
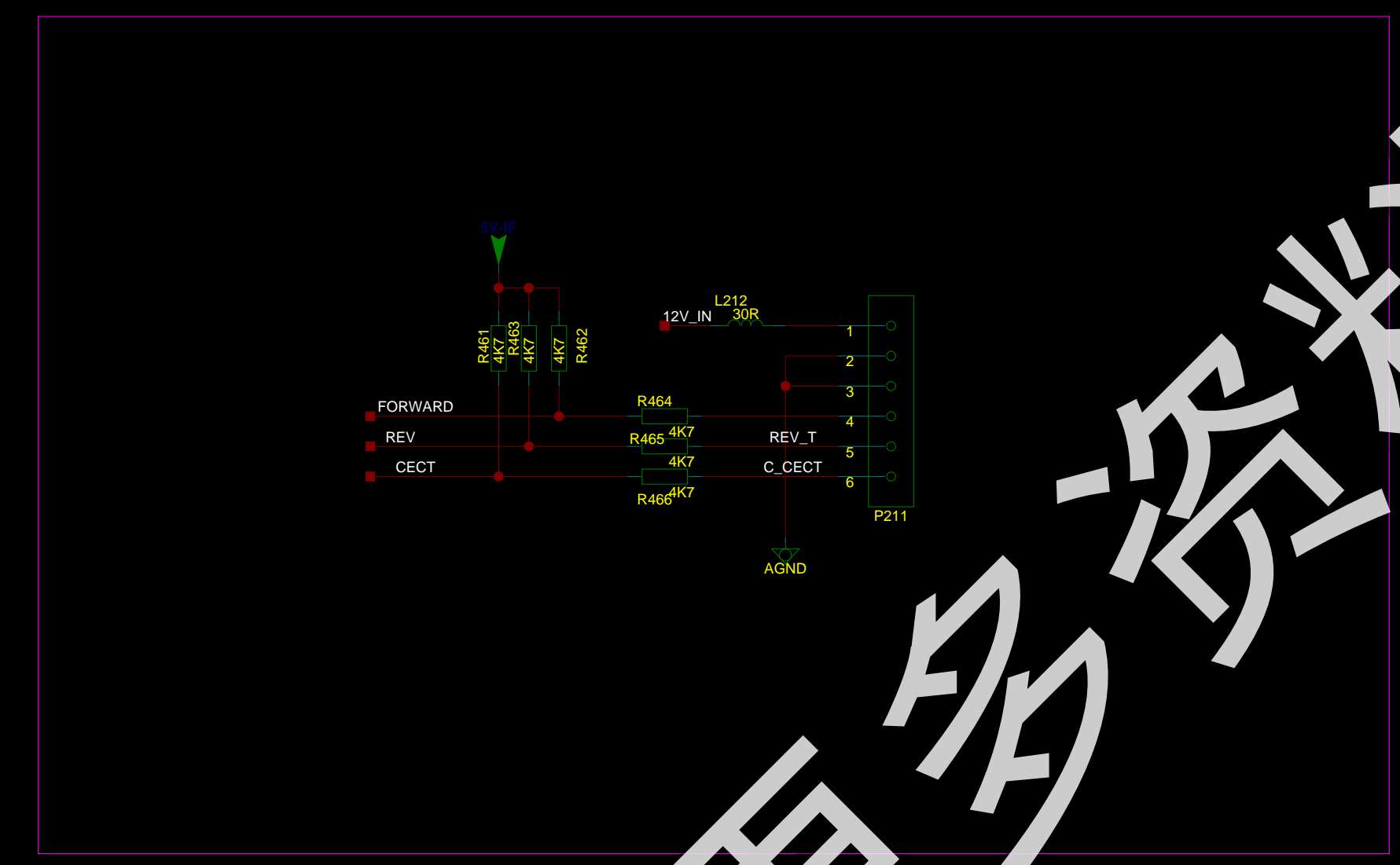

获取更多资料
微信搜索 蓝屏星球

...	DD-MM	SBU :
...	DD-MM	TCLNO:
...	DD-MM
...	DD-MM	DESIGNATION
Index-Lab	DATE	NAME	DESCRIPTION	Last modif	DVD-COMB/CAMERA
Last saved : 5-5-2008_16:29					

DESIGNATION
DVD-COMB/CAMERA

TTE
TCL Thomson Electronics Ltd.
B Building, TCL Tower, Nanhai Road
Nanshan District, Shenzhen, Guangdong
Tel +86-755-3331xxxx Fax +86-755-3331xxxx

DRAWN	CHECKED	PAGE:
ON:	ON: DD-MM-YY	OF :
BY:	BY:	

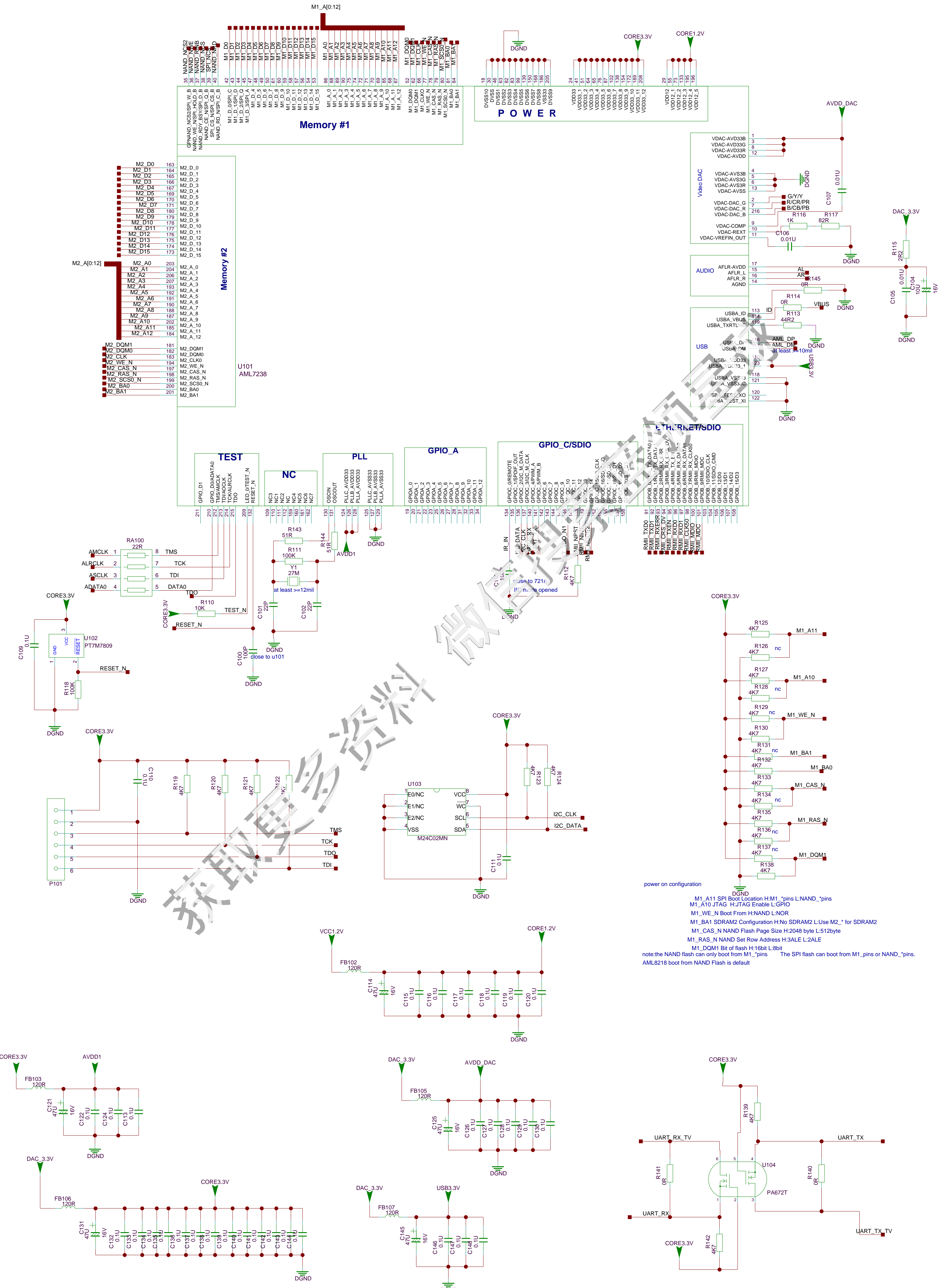

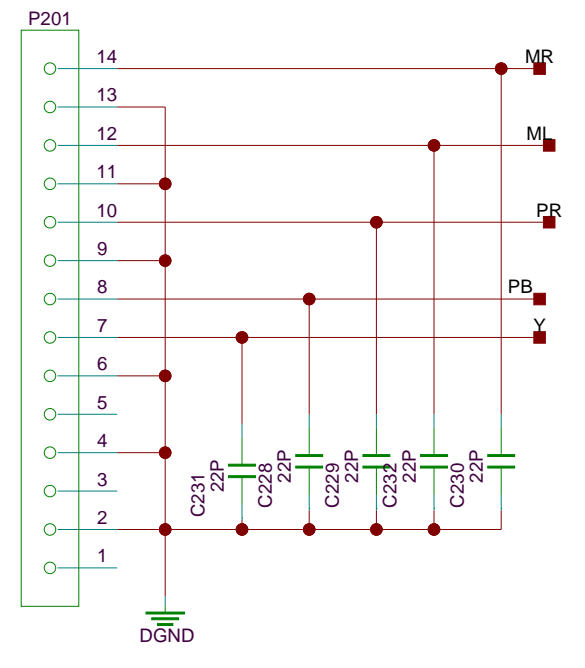
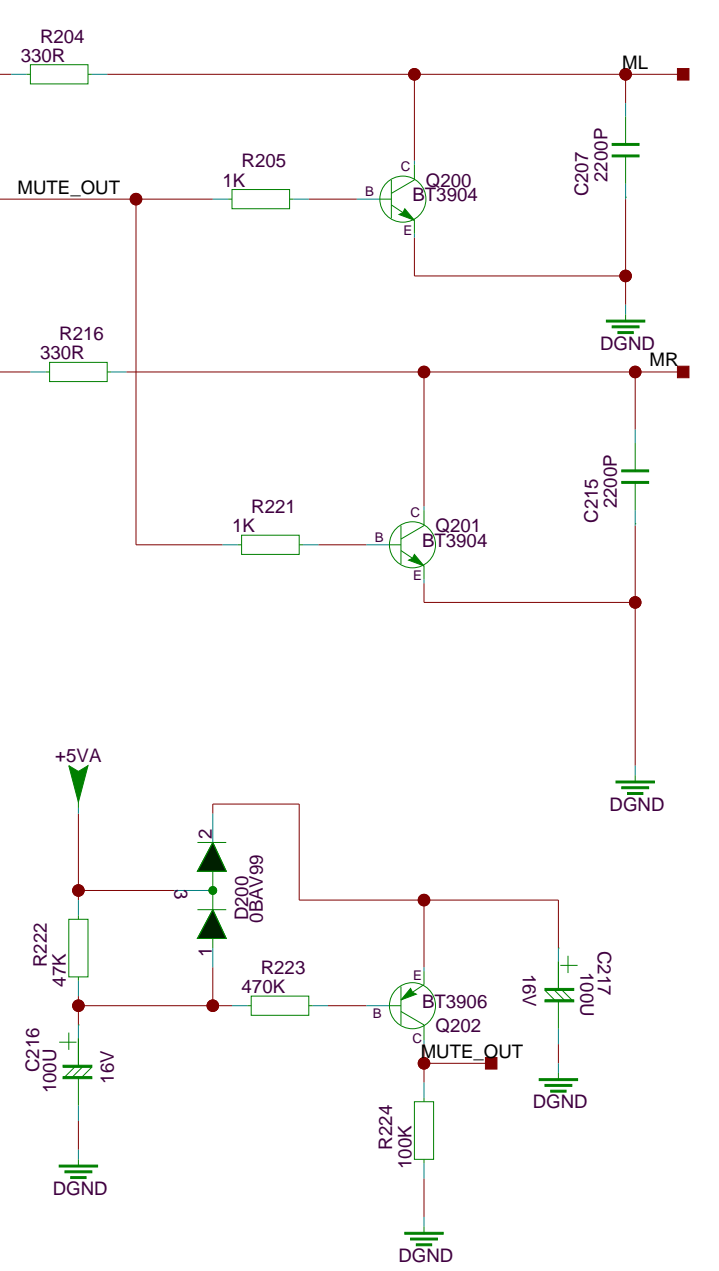
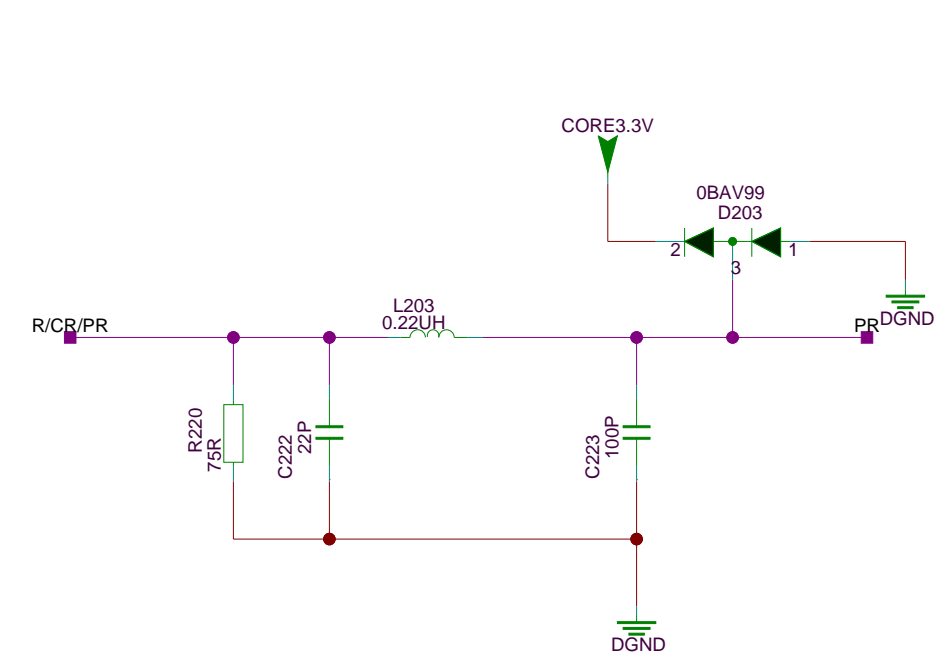
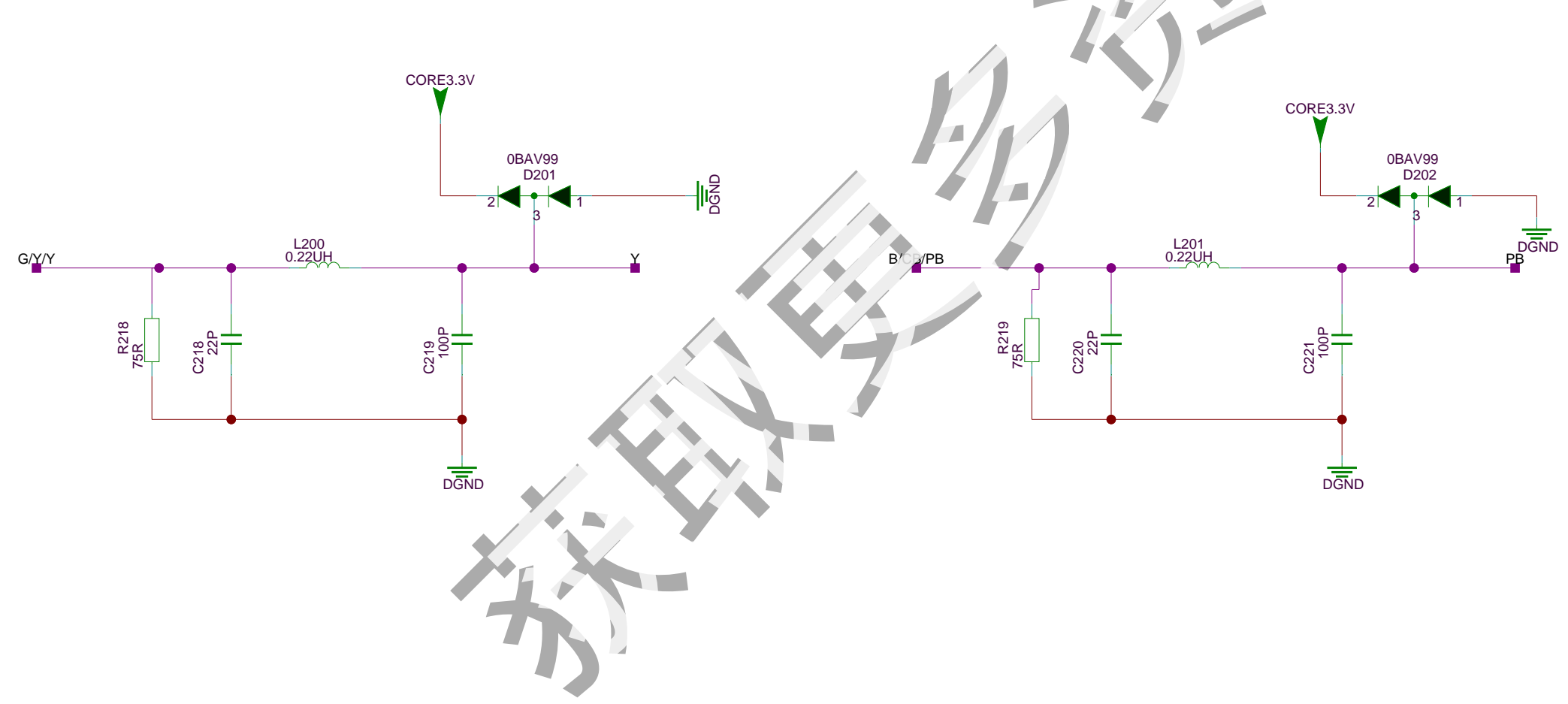
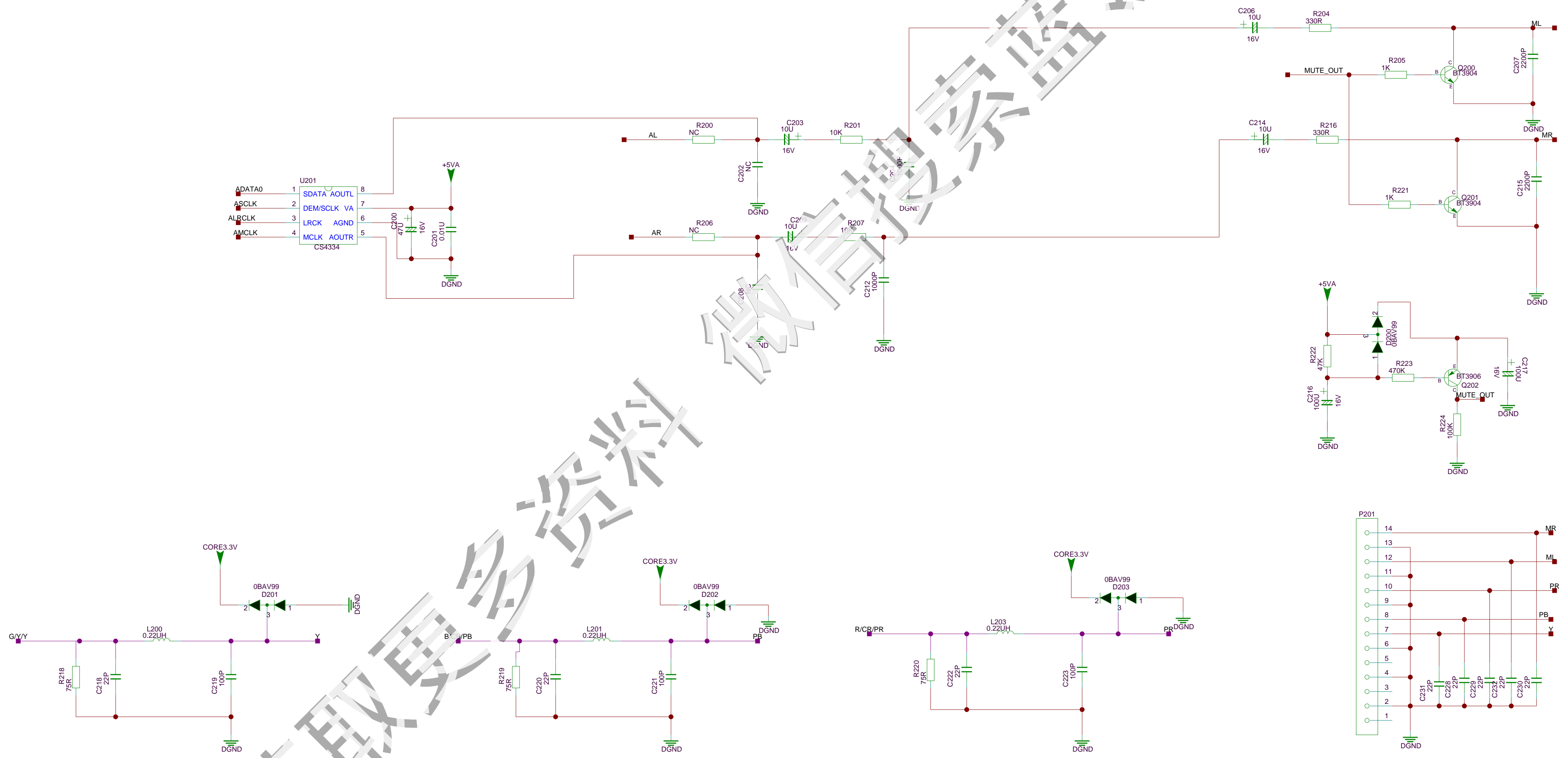

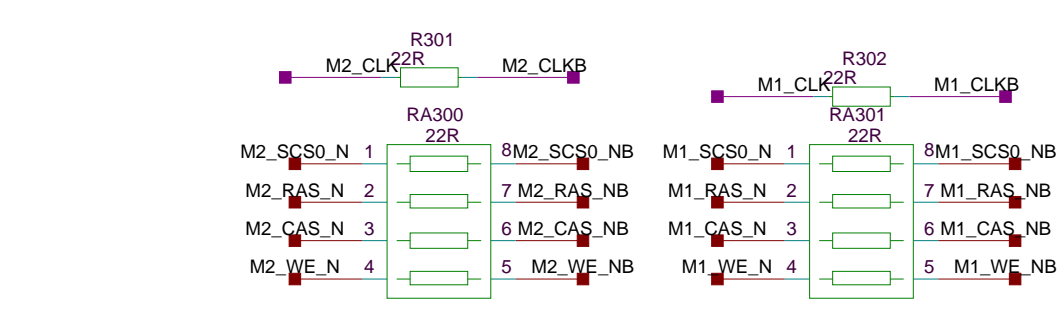
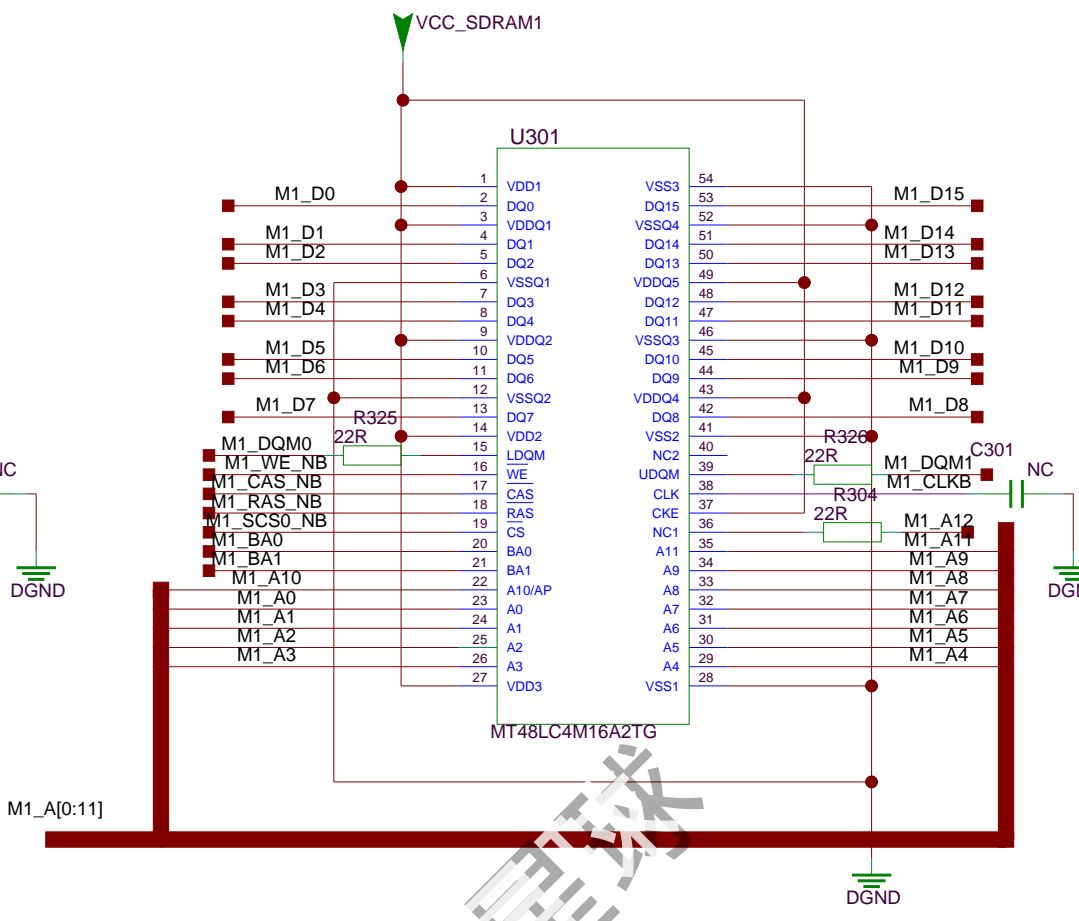
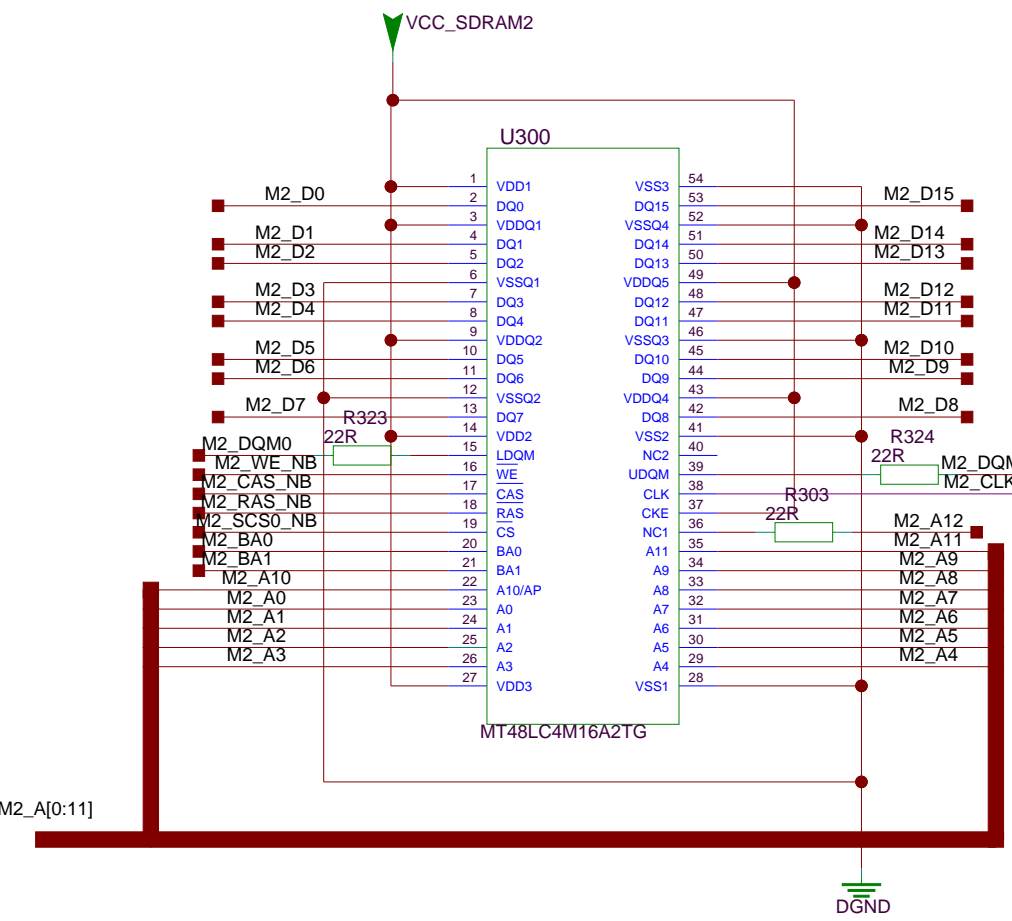

closed to AML7218

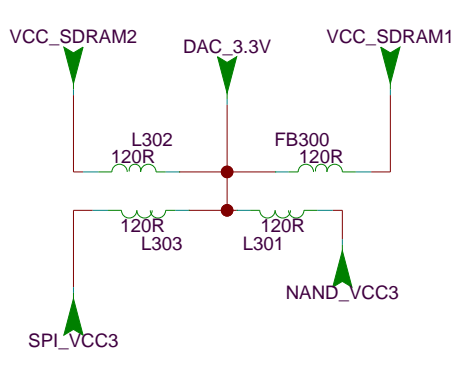
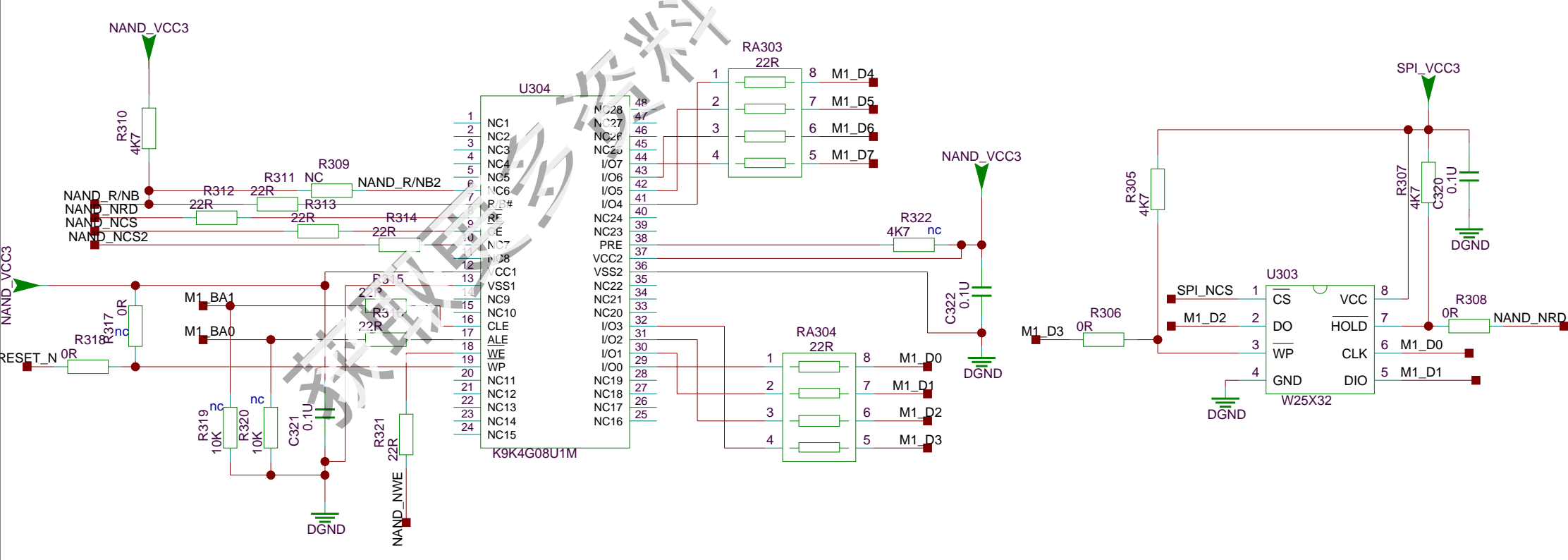
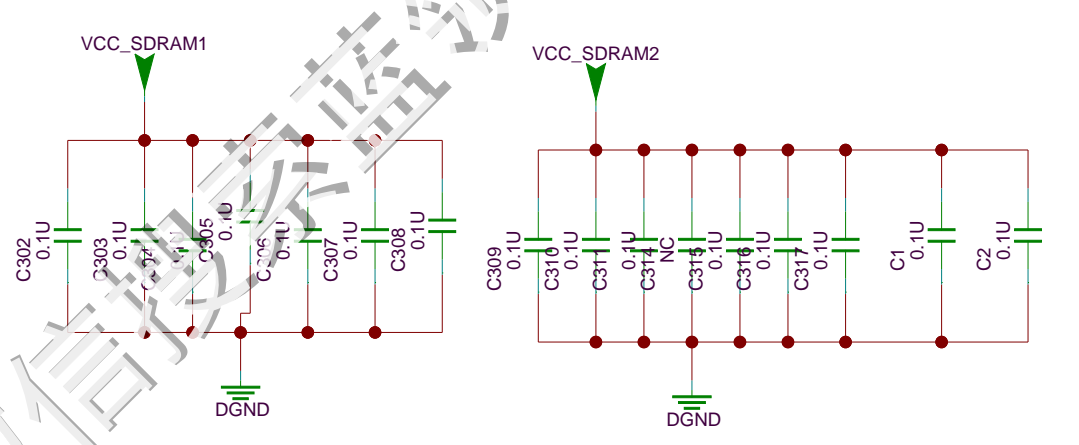

NEW 6 HOLE BOARD IS CHANGED TO THIS 10 PINS CONNECTOR

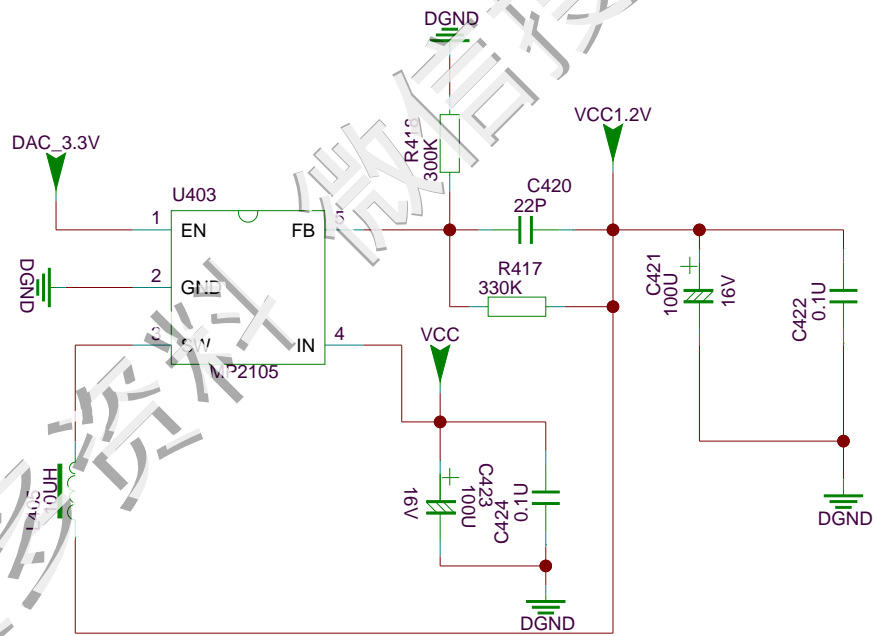
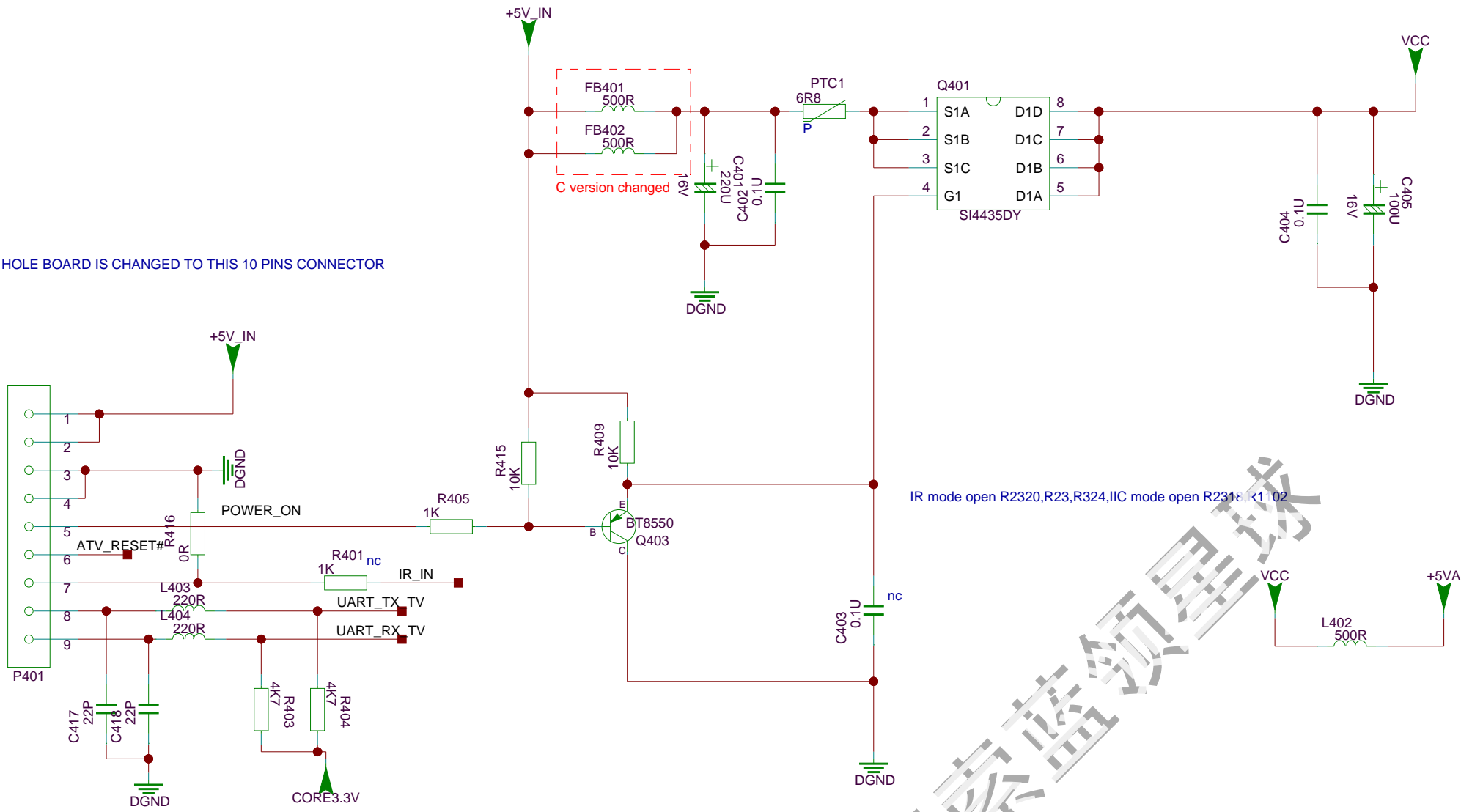

获取更多资料
微信搜索 蓝领星球

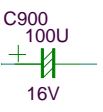
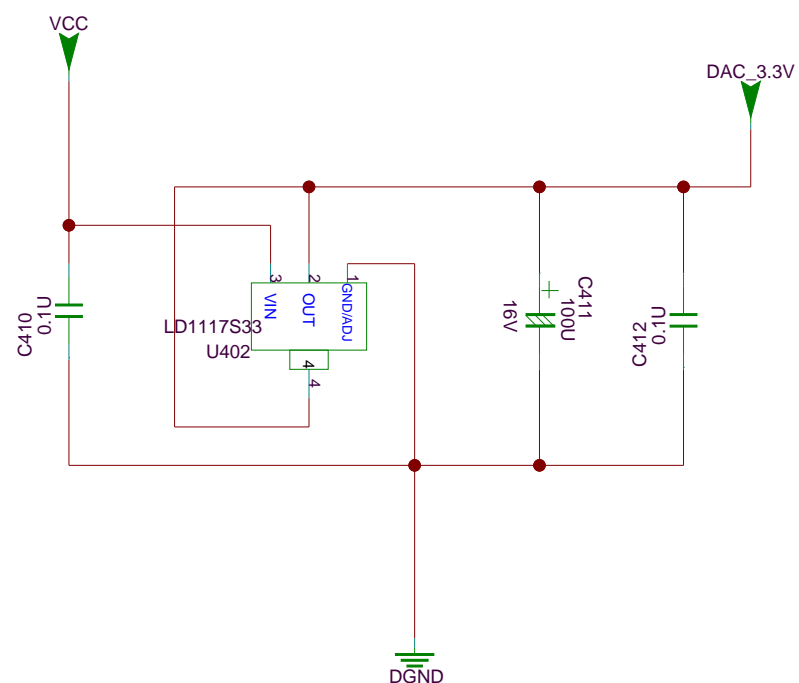

c version add T1 and T2 for EMC filter

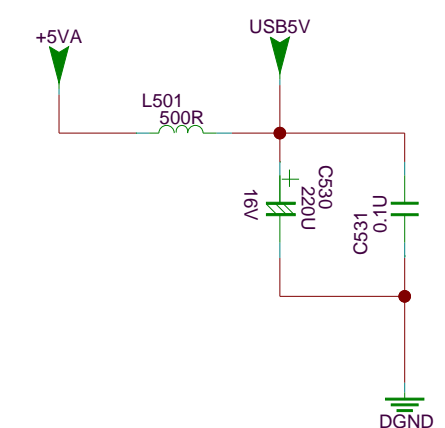
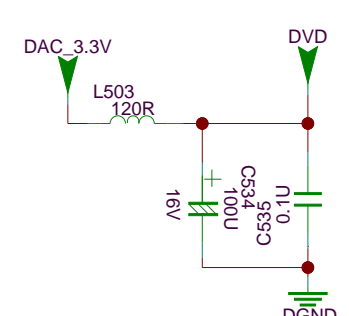
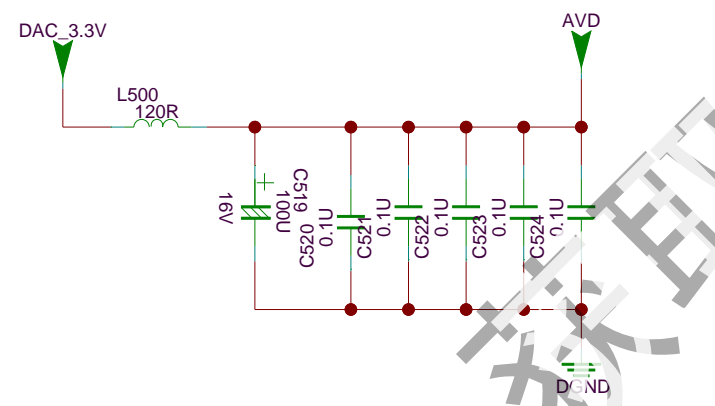
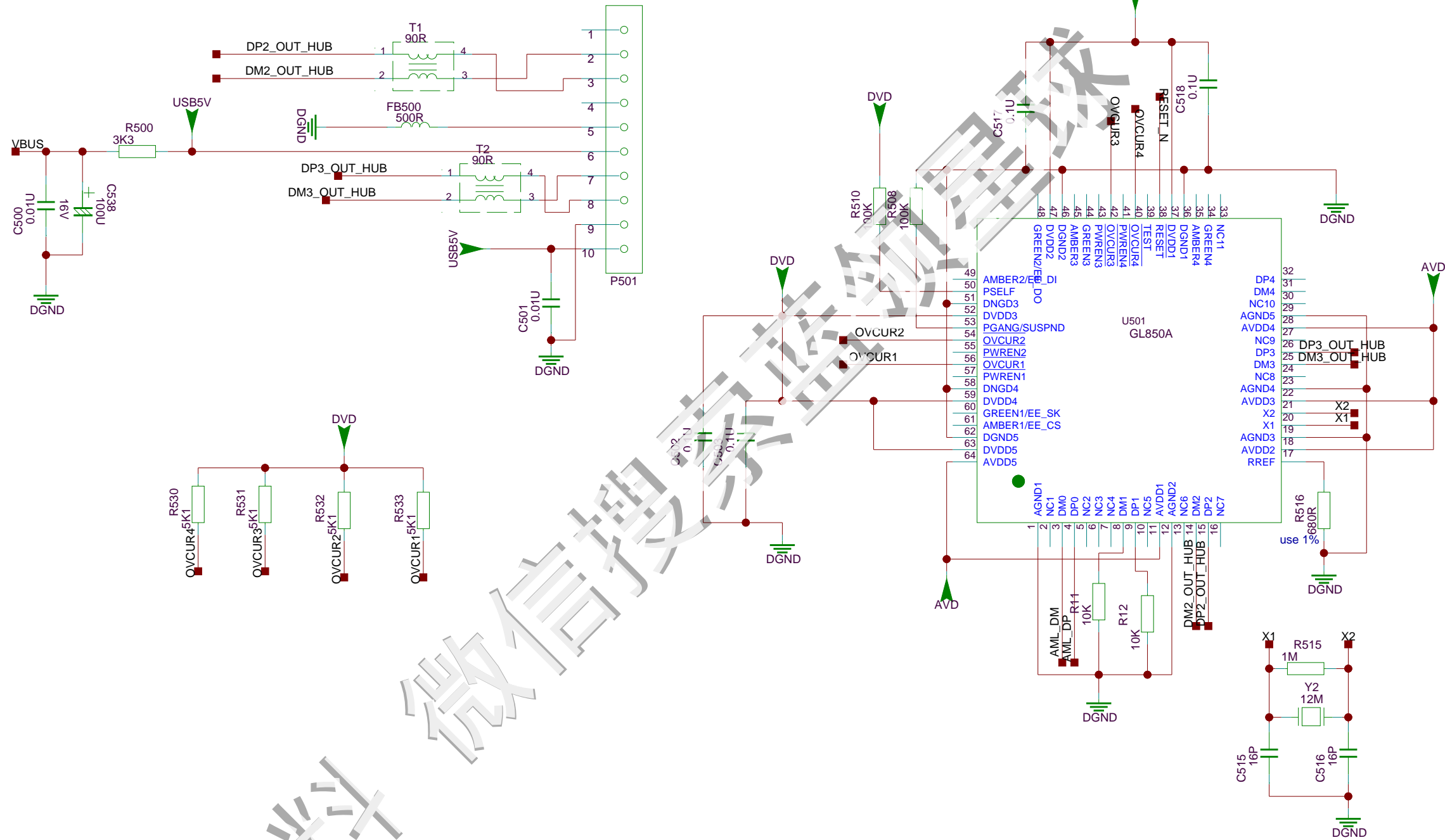

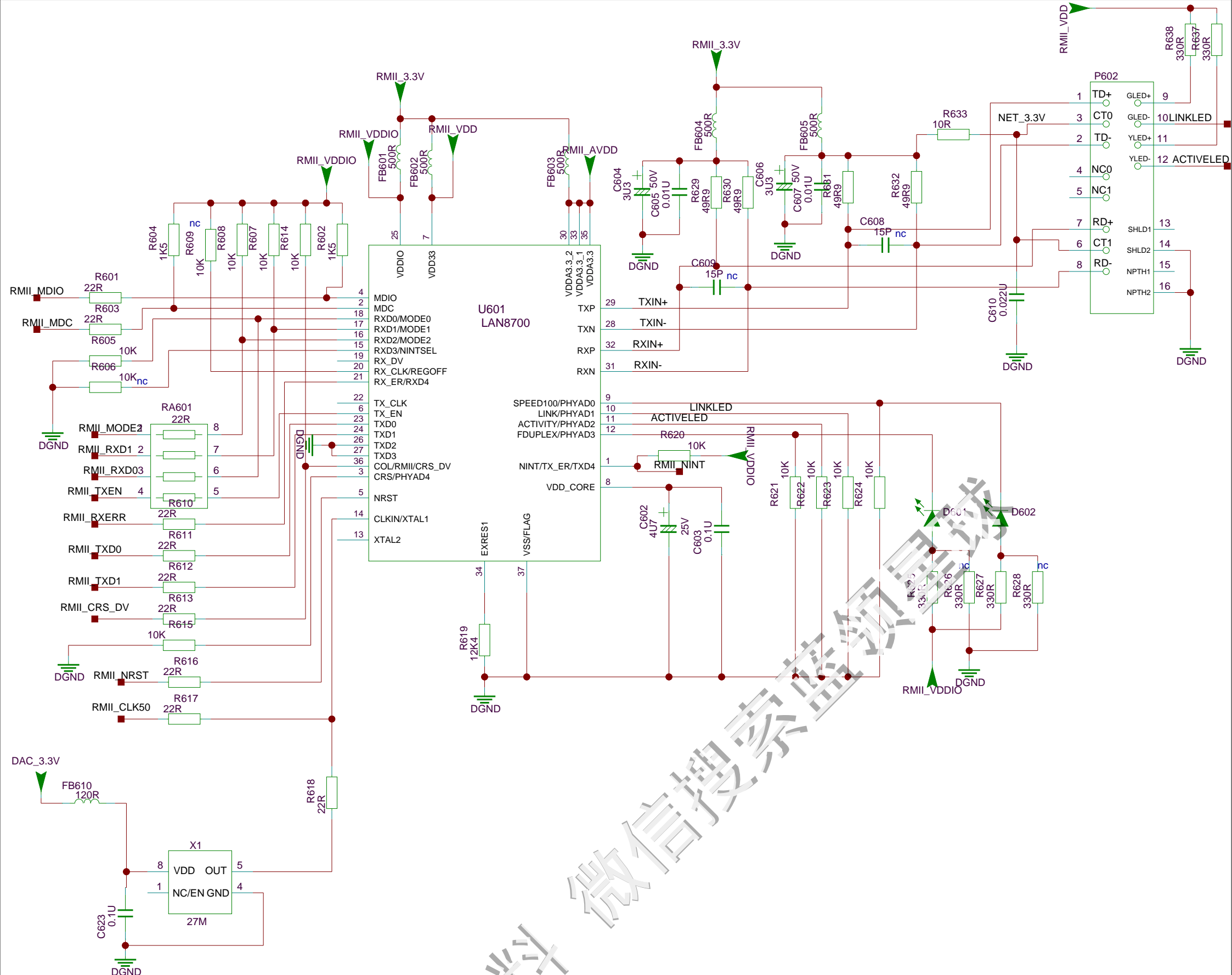

获取更多资料
 微信搜索盛芯网

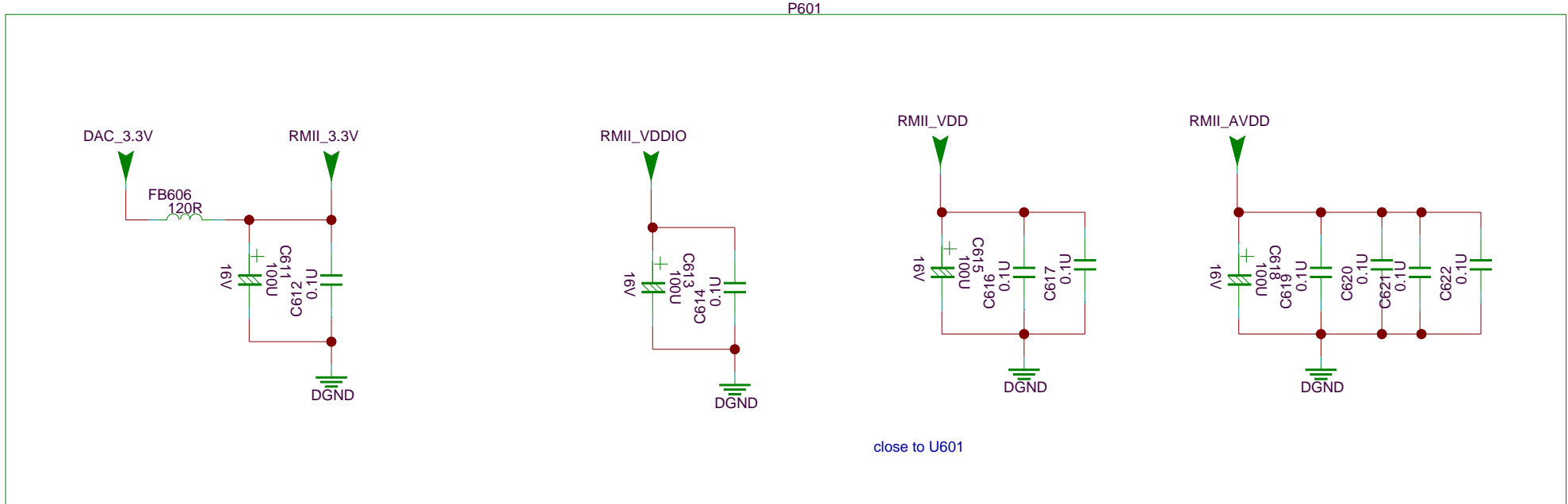
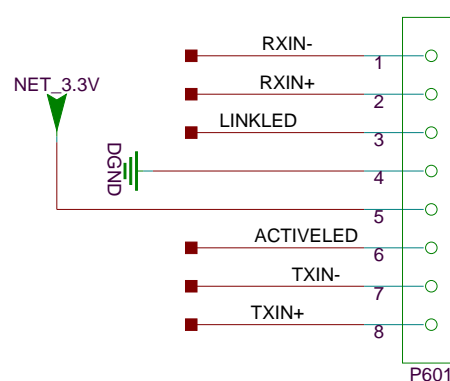

close to U601