

# 制冷空调领域，世界的先驱

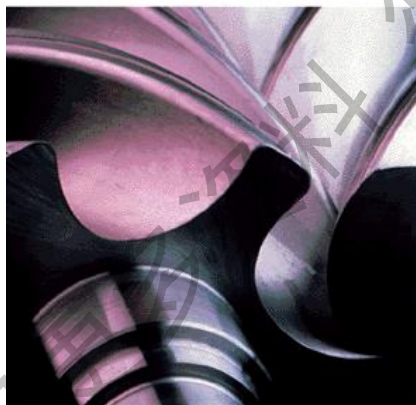
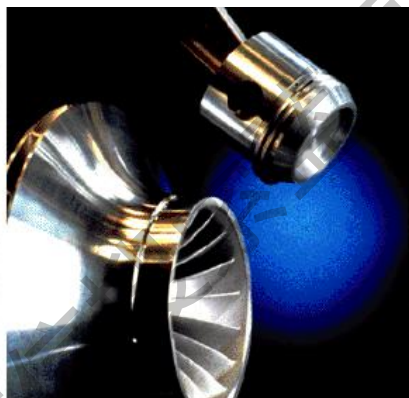
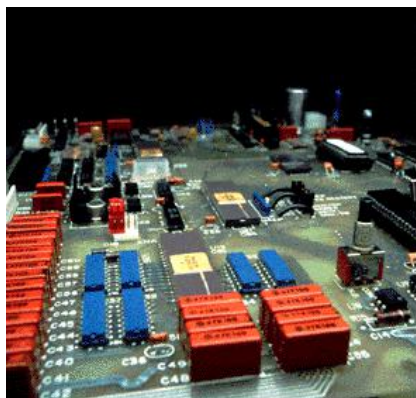

 **YORK** INTERNATIONAL  
CORPORATION

# Millennium<sup>tm</sup> 水冷螺杆式冷 水机组

---



获取更多资料 微信搜索蓝领星

# Millennium<sup>tm</sup> 水冷螺杆式冷 水机组



- 100~1050TR  
(使用 HCFC-22)
- 100~300TR  
(使用 HFC-134a)
- YORK ISN<sup>tm</sup>控制

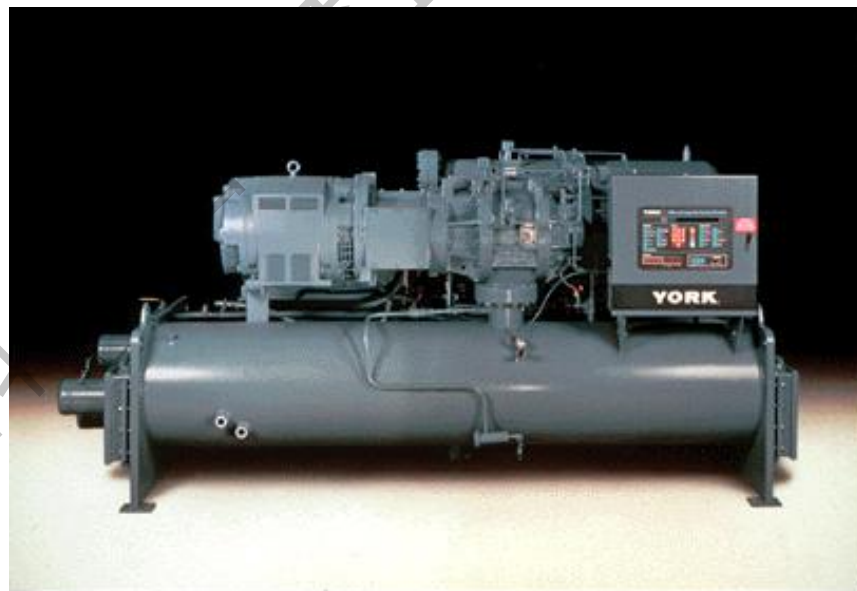

获取更多信息

# 开式电机驱动 节省能耗

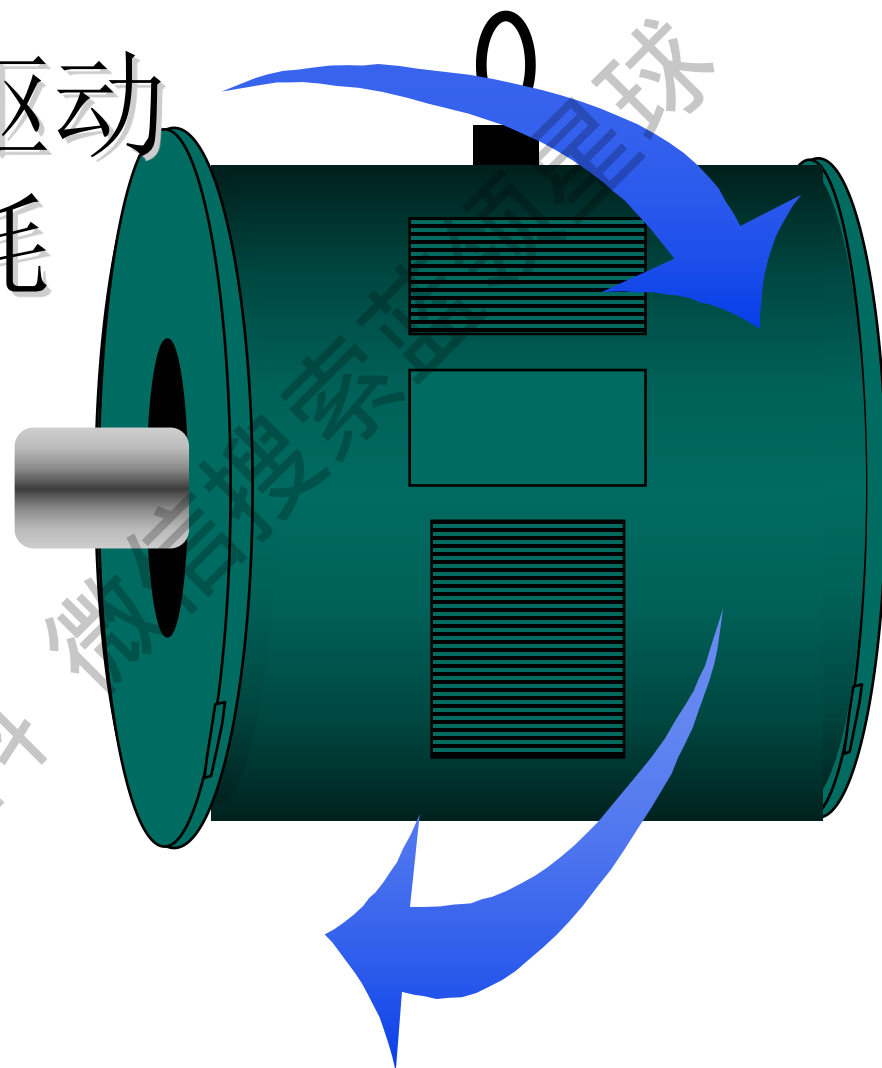

- 电机由机房通风冷却，散热量不  
带  
入制冷系统，  
系统效率可提高  
约3%。

获取更多资料

# YS Millennium<sup>tm</sup> 冷水机组



封闭式电机烧毁时会造成整个系统的严重污染

可靠性高——开式马达设计可避免封闭式马达的烧毁事故



29.4°C

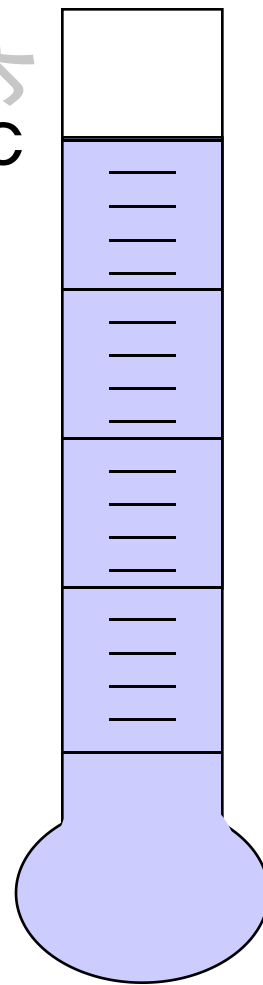

# 冷却水温度降低 可节省能源费用

约克机组可低至**12.8 C**的冷却  
水进水

# 降低冷却水温度

压缩机先生

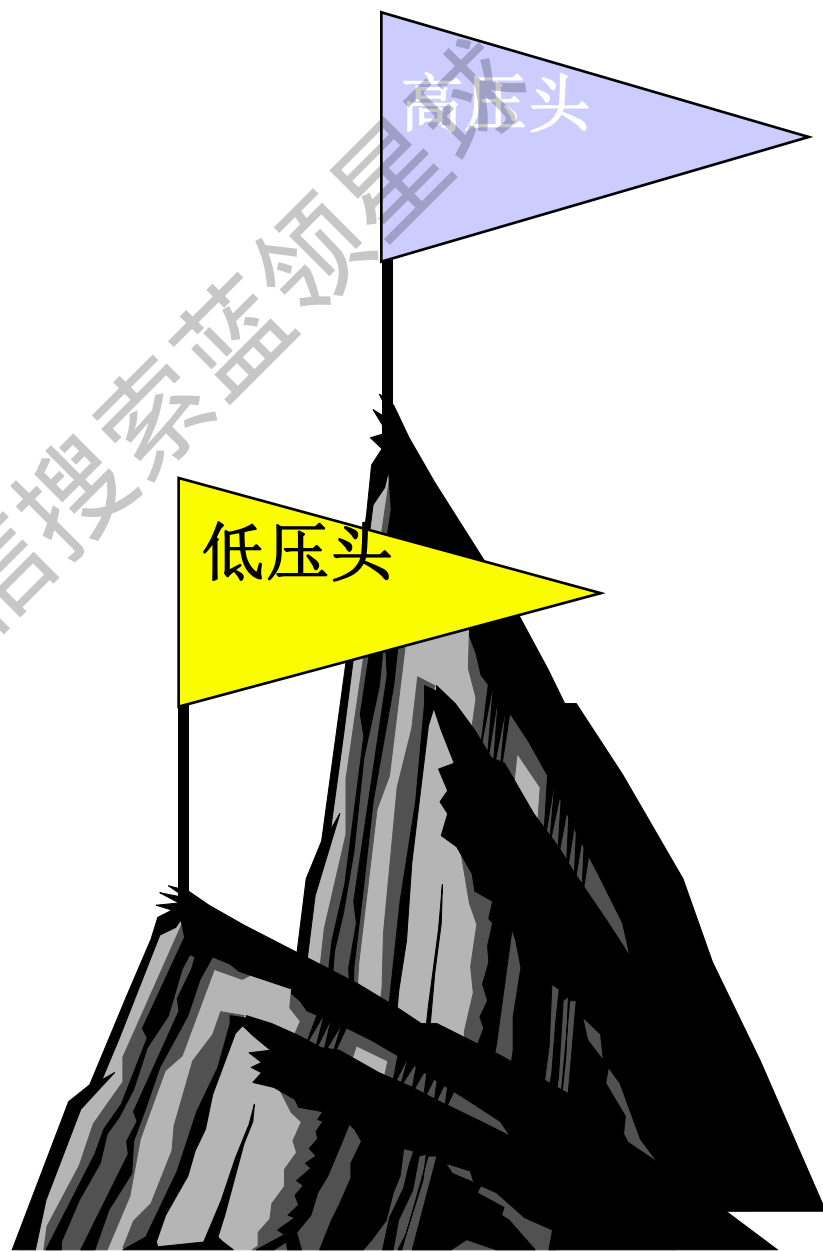

# 约克冷水机组 按 $12.8^{\circ}\text{C}$ 冷却 水温度设计

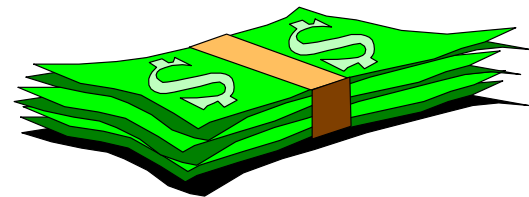

能源费用

获取更多资料

微信公号蓝领星球



# 冷却水进口温度降低 给对手带来的问题

- 油留在冷媒回路

来自冷凝器的冷媒

kPa

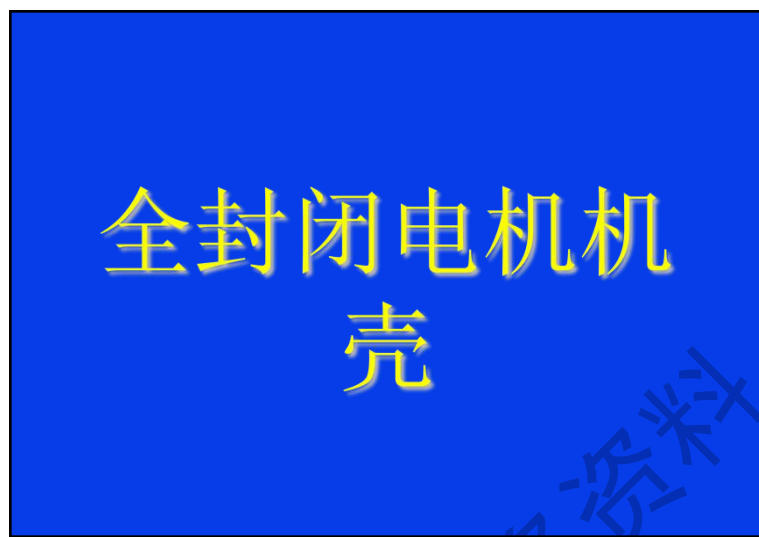

冷媒去往节能器&蒸发器

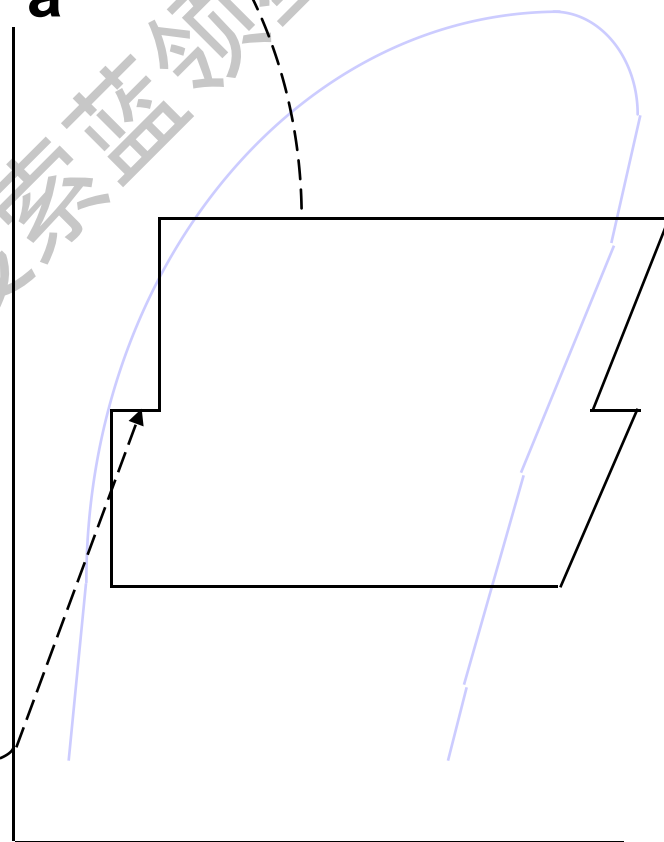

焐

细看...

# 全封闭电机机壳

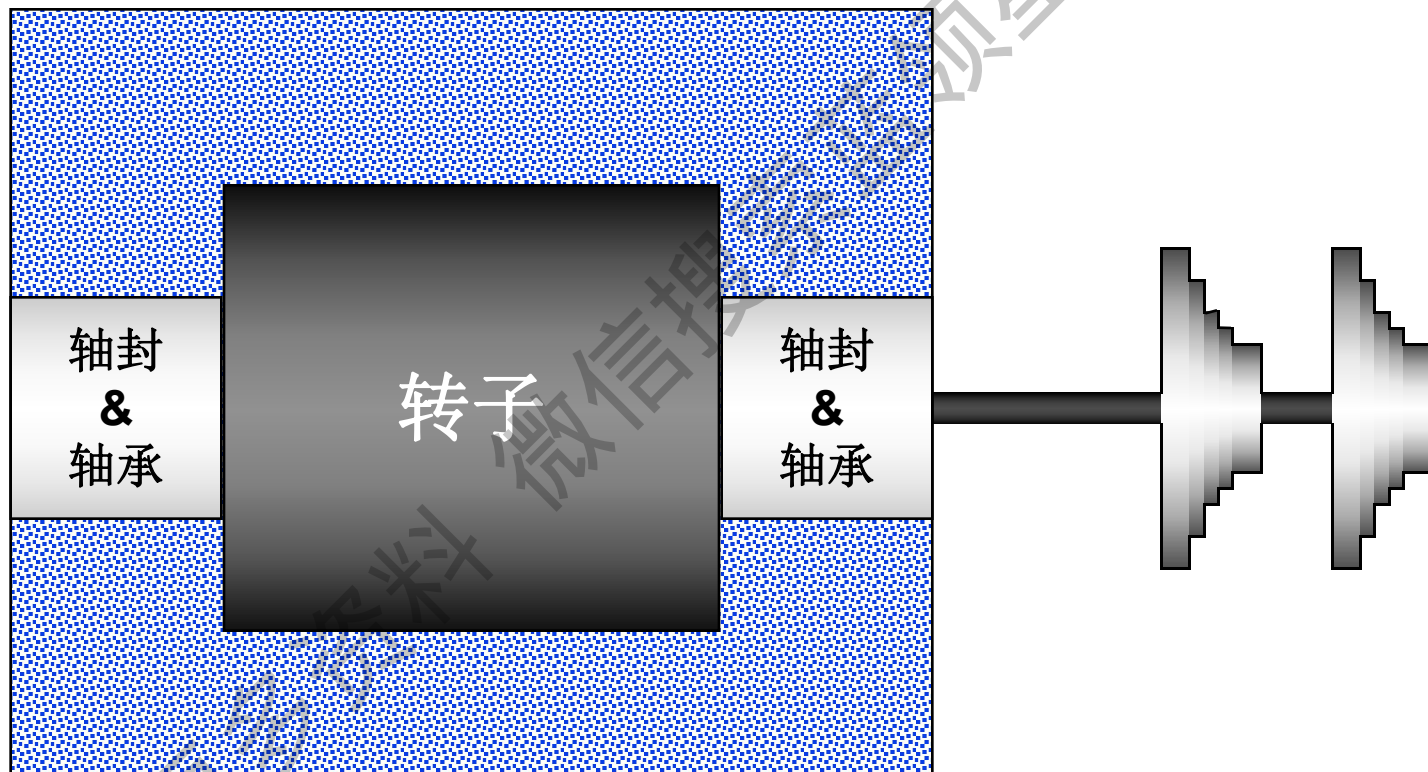

获取更多资料 微信搜索 领星球

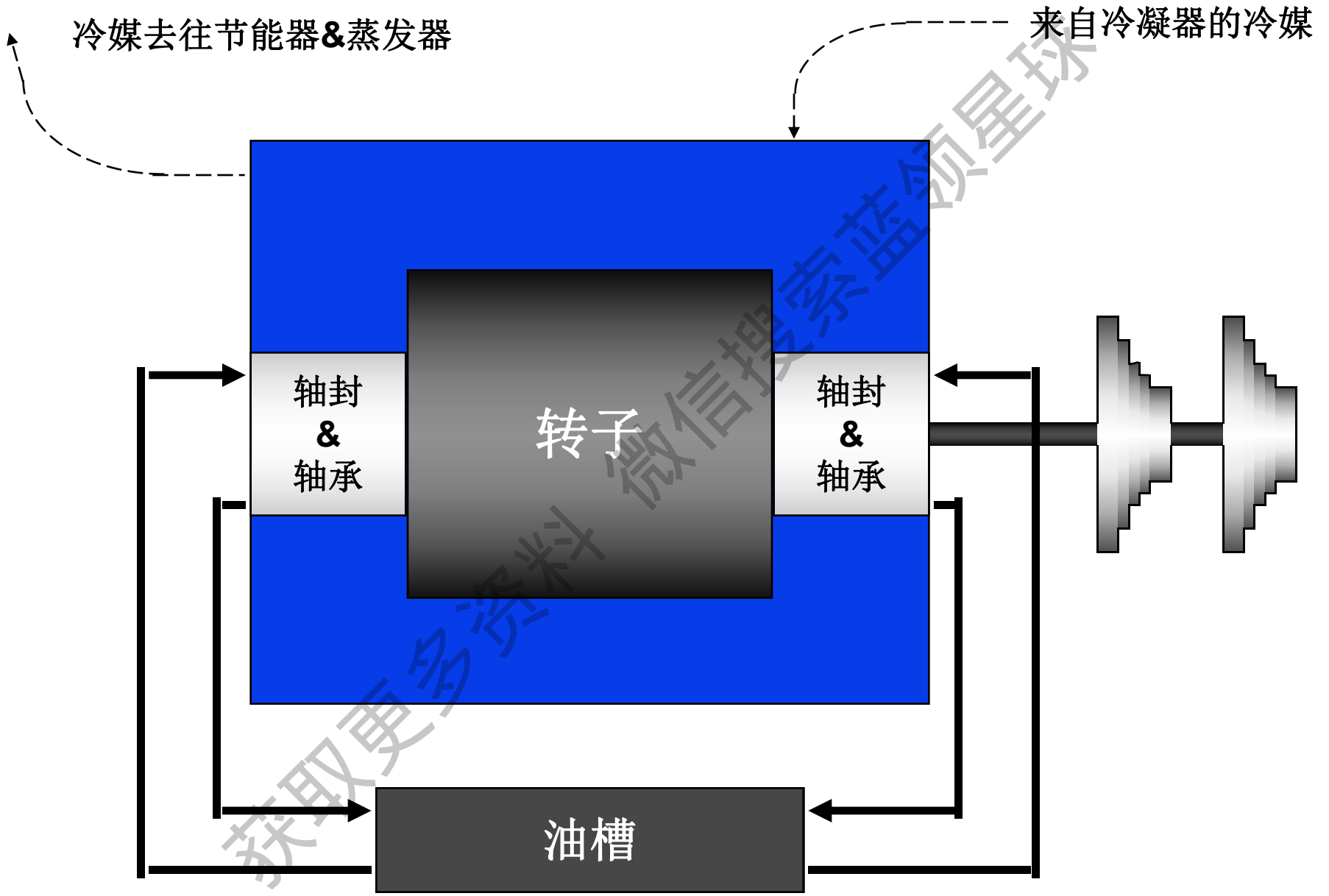

冷媒去往节能器&蒸发器

来自冷凝器的冷媒

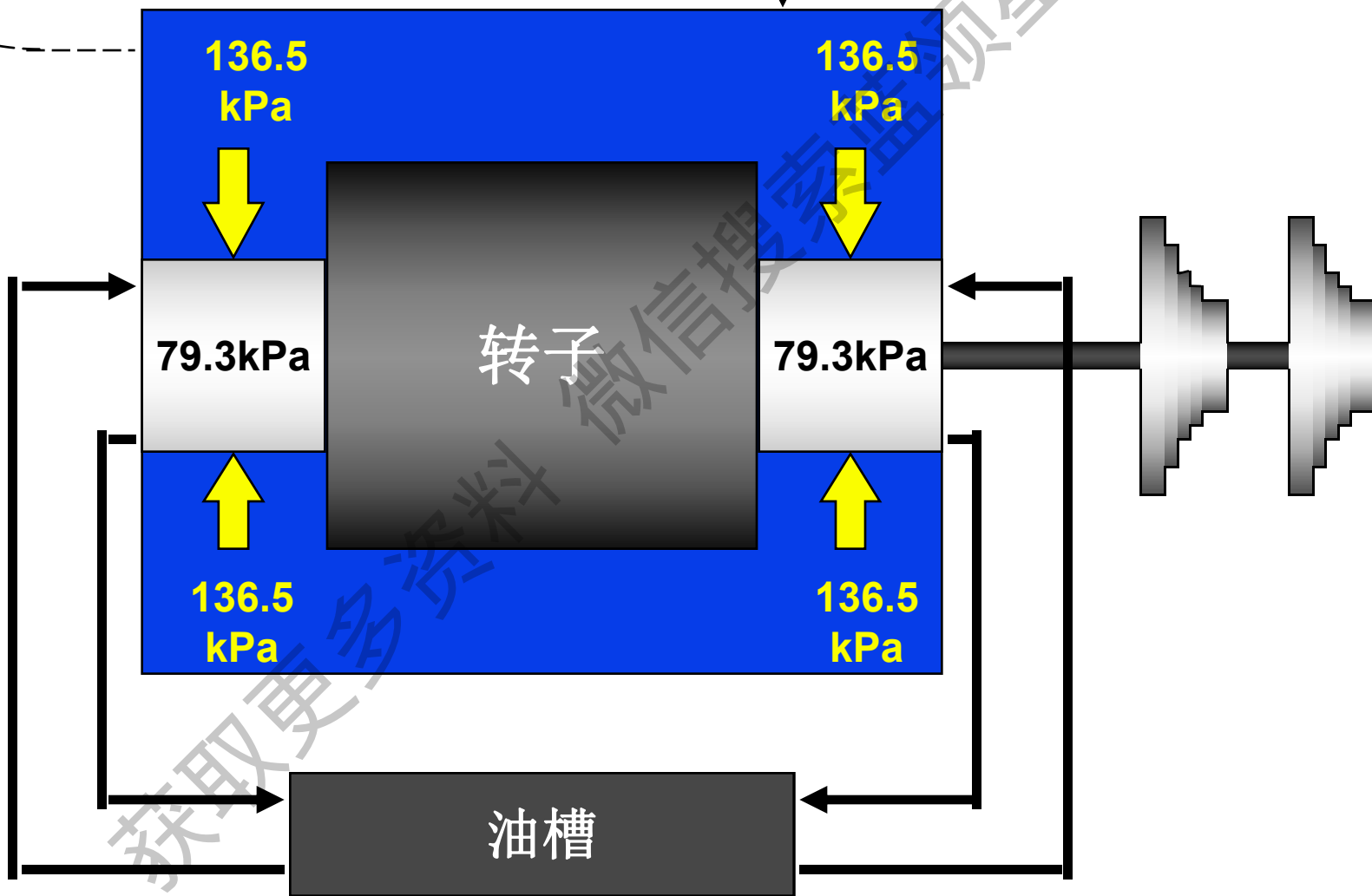

冷媒去往节能器&蒸发器

来自冷凝器的冷媒

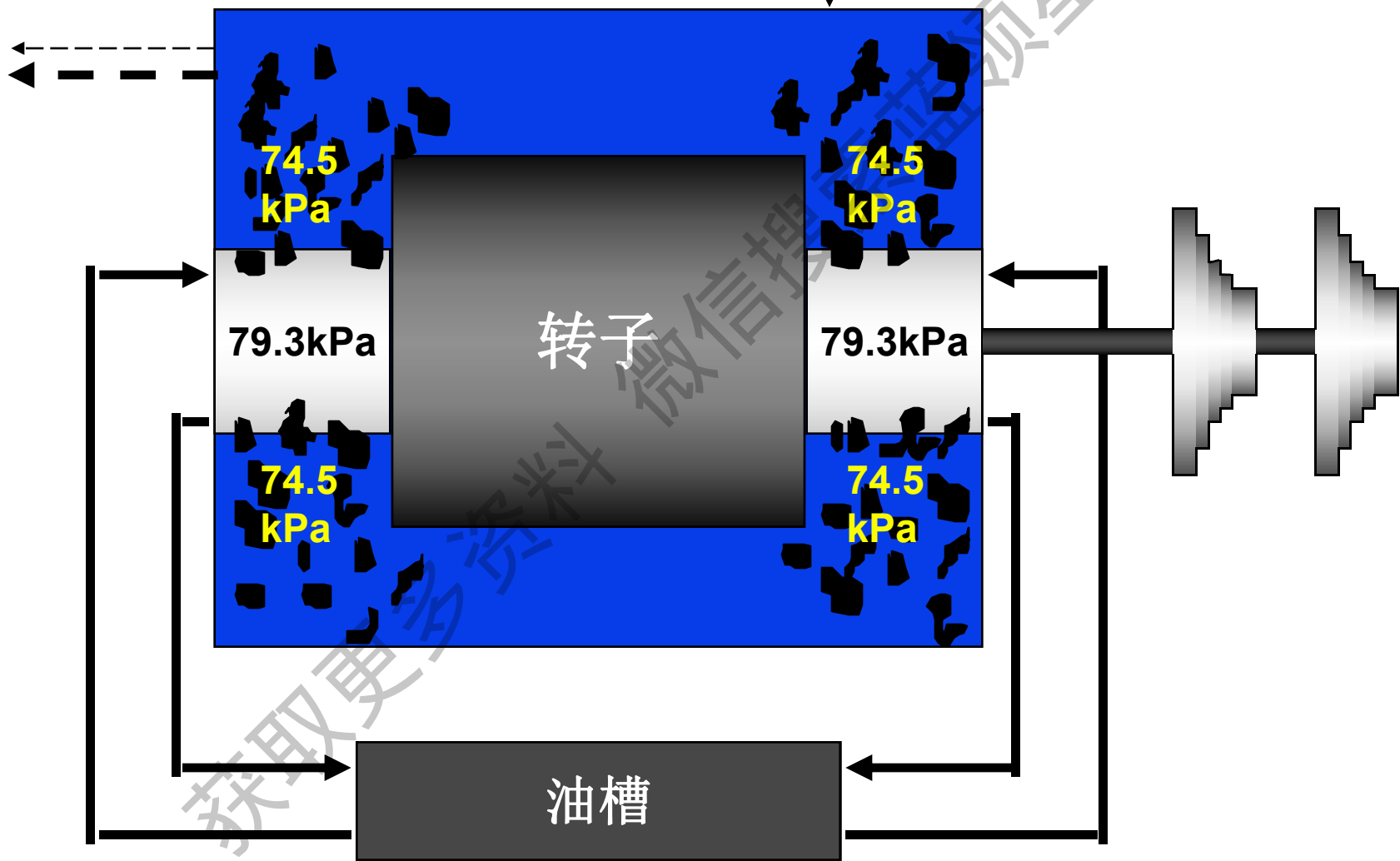

- 双面强化换热铜管
- 管板支撑刚度强

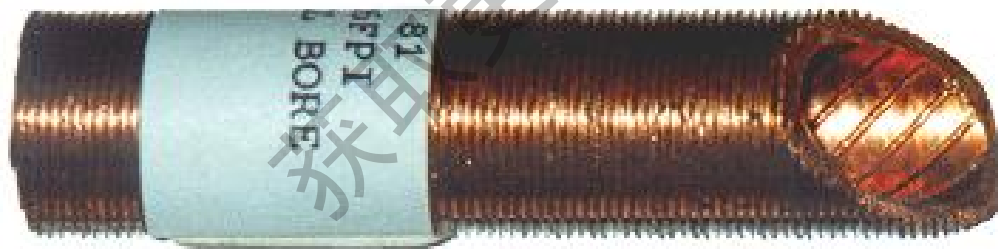

Water Flow  
水流方向

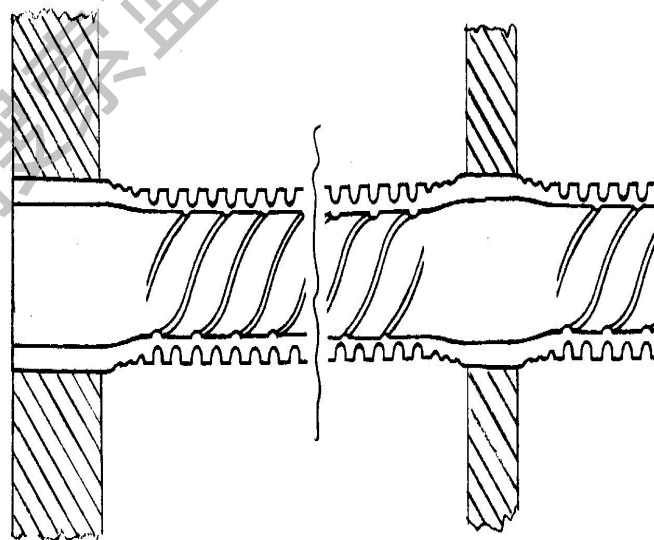

Tube  
Tube Sheet  
端板

Tube  
Tube Support  
管板

# Millennium<sup>tm</sup> 水冷螺杆式冷水机组

---



- 设计特点

- 开式马达设计
- 双螺杆压缩机
- 中文微电脑控制
- 双油槽设计
- 高效热交换器
- 蒸发器与冷凝器使用Skip-fin强化换热铜管
- 蒸发器上装有视液镜
- 冷凝器隔离阀



# Millennium™ 水冷螺杆式冷水机组

---

- FRICK双螺杆压缩机
- FRICK是世界著名螺杆机生产厂，YORK全资子公司



# Millennium<sup>tm</sup> 水冷螺杆式冷水



## 机组

- 双油槽设计
- 重力供油，启动，停机时仍有可靠润滑

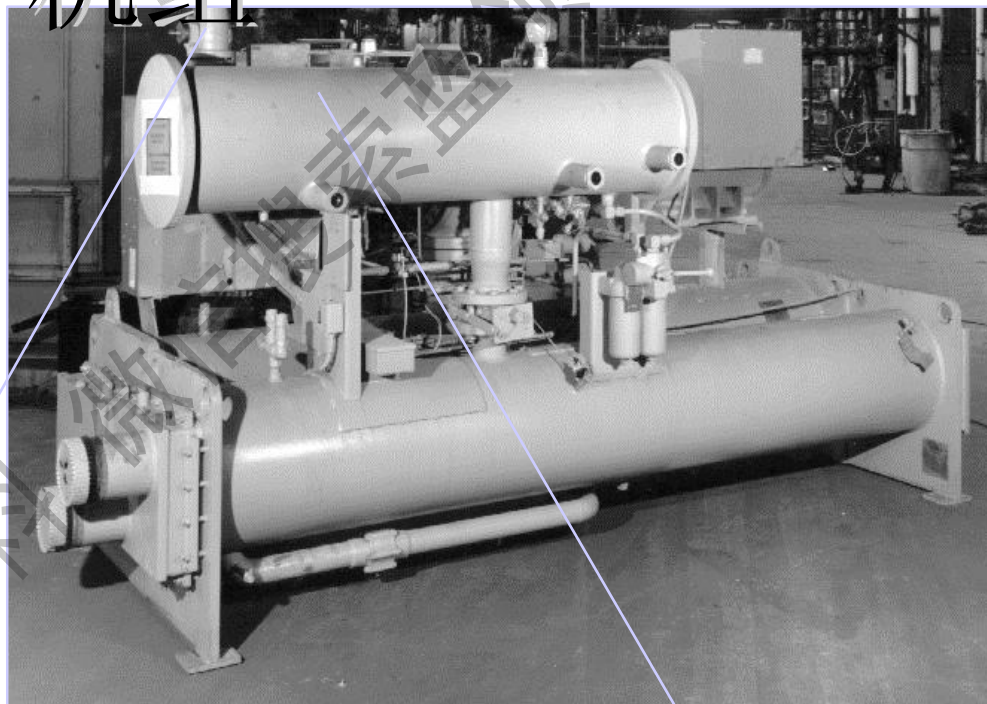

压缩机内备用油槽

主油槽：  
油分离器

# Millennium<sup>tm</sup> 水冷螺杆式冷水机组

---



- 卸载，上载原理

获取更多资料

微信搜索蓝领星

# Millennium<sup>tm</sup> 水冷螺杆式冷水机组

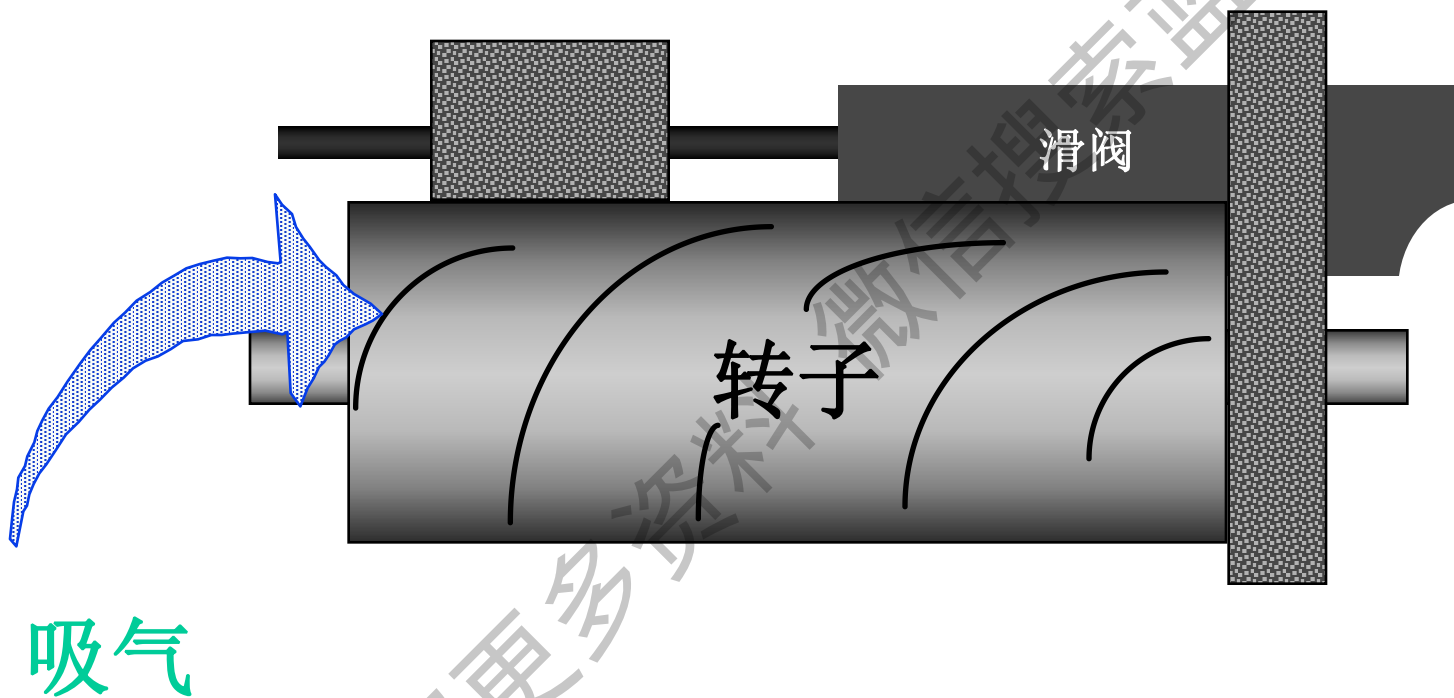

获取更多资料

微信搜索蓝领星

# Millennium<sup>tm</sup> 水冷螺杆式冷水



## 机组

部分负荷 (滑阀开)

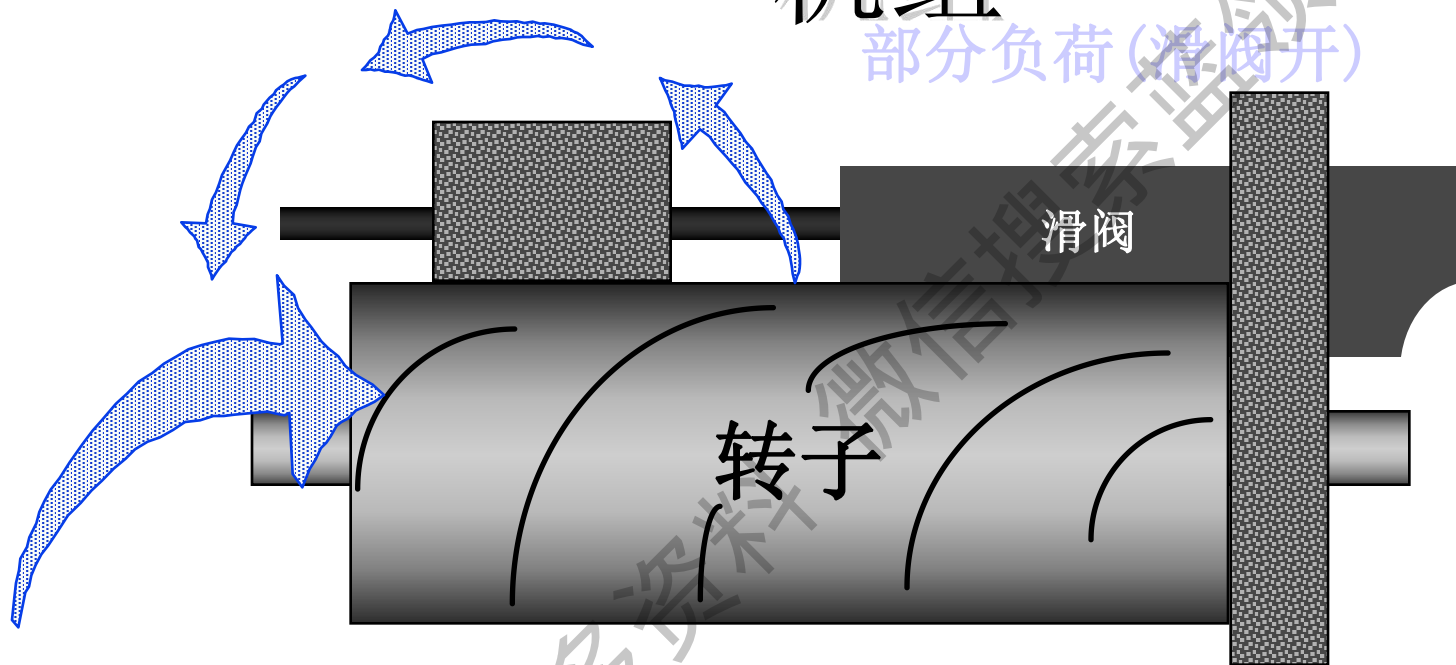

吸气

获取更多资料

# Millennium<sup>tm</sup> 水冷螺杆式冷水机组



## 机组

部分负荷 (滑阀开)

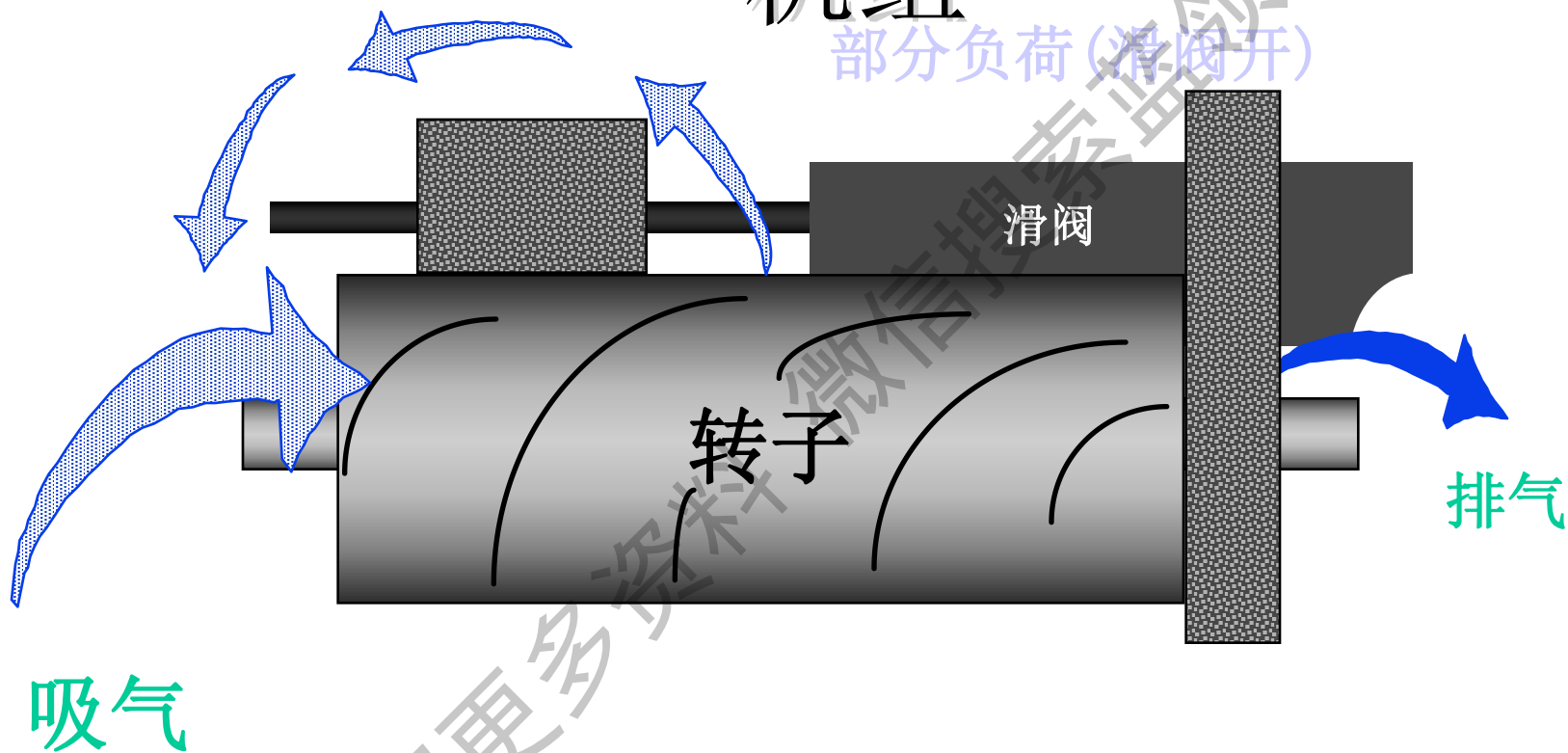

获取更多资料

# Millennium<sup>tm</sup> 水冷螺杆式冷水机组



## 机组

满负荷 (滑阀关)

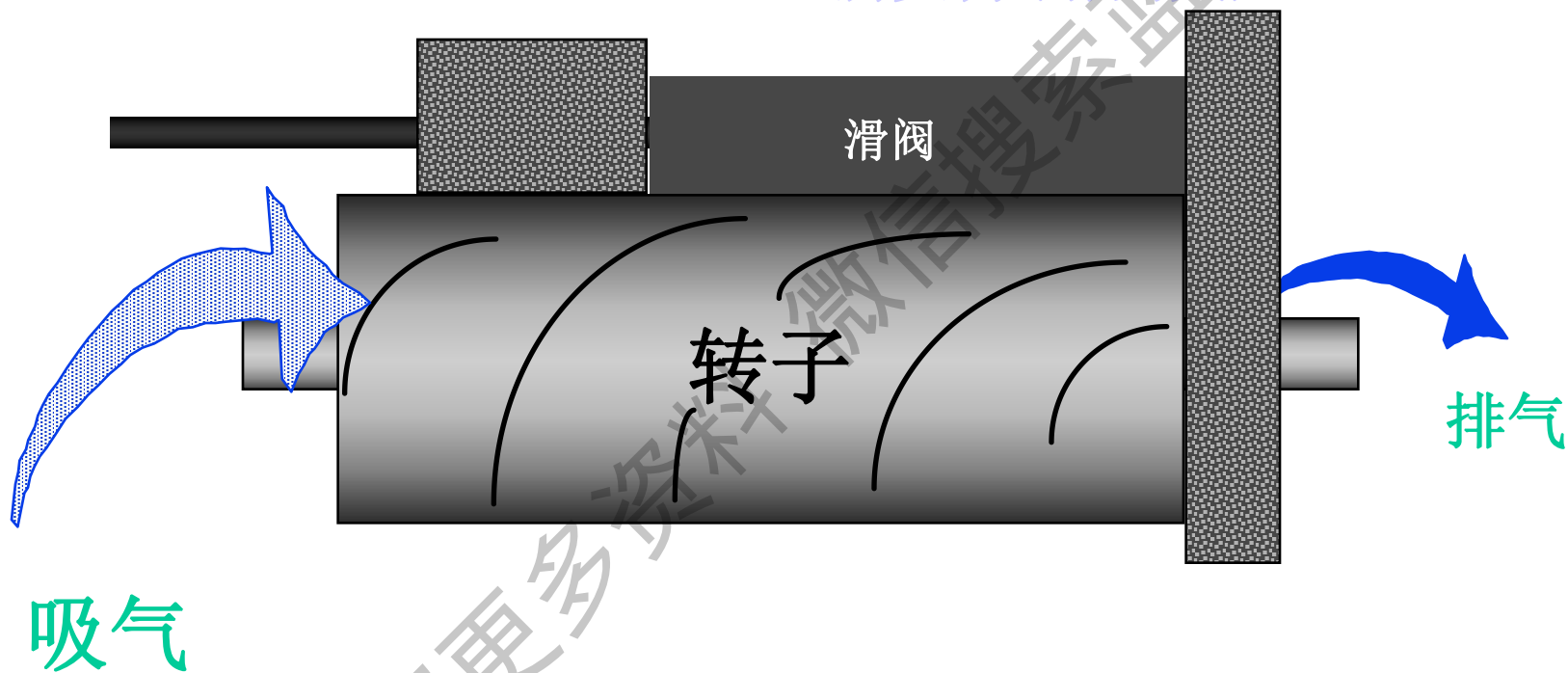

获取更多资料

# Millennium™ 水冷螺杆式冷水机组



## 机组

满负荷 (滑阀关)

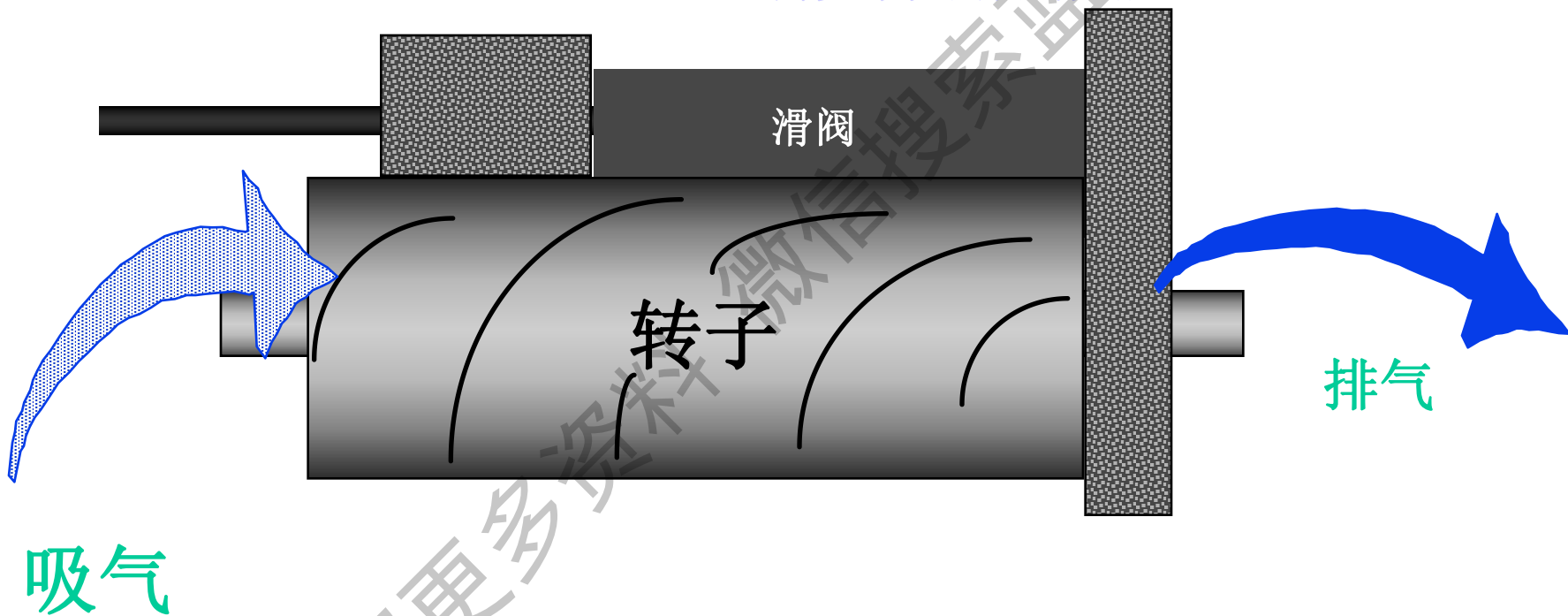

获取更多信息



# Millennium<sup>tm</sup> 水冷螺杆式冷水机组



- 轴封

轴封盖

高压油腔

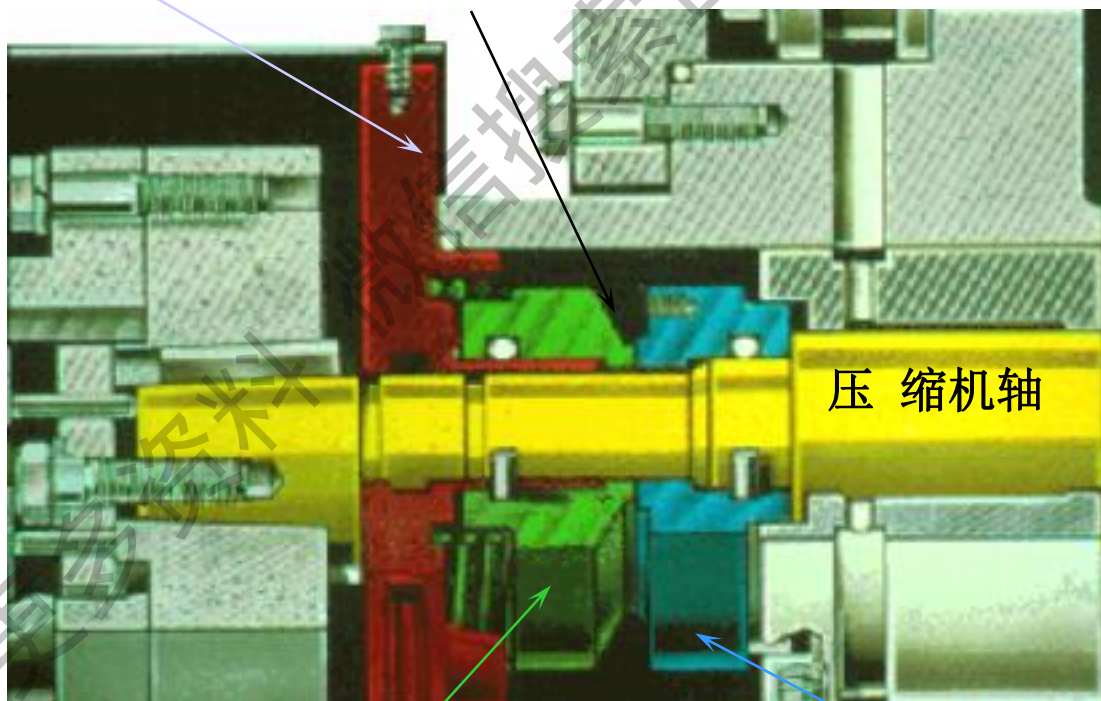

压缩机轴

非运动件

运动件

# Millennium<sup>tm</sup> 水冷螺杆式冷水



## 机组

- 冷凝器
- 散流板
- 铜管强化换热
- 过冷器

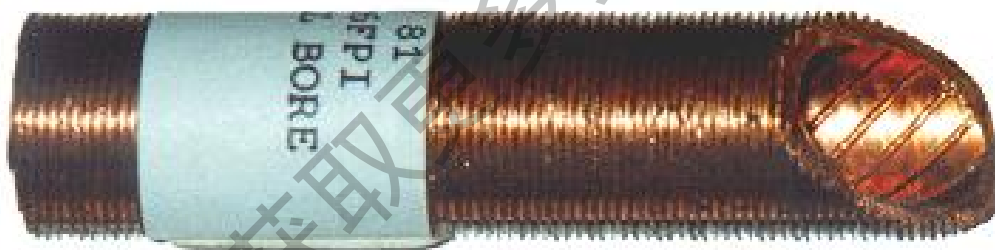

# MILLENNIUM机组

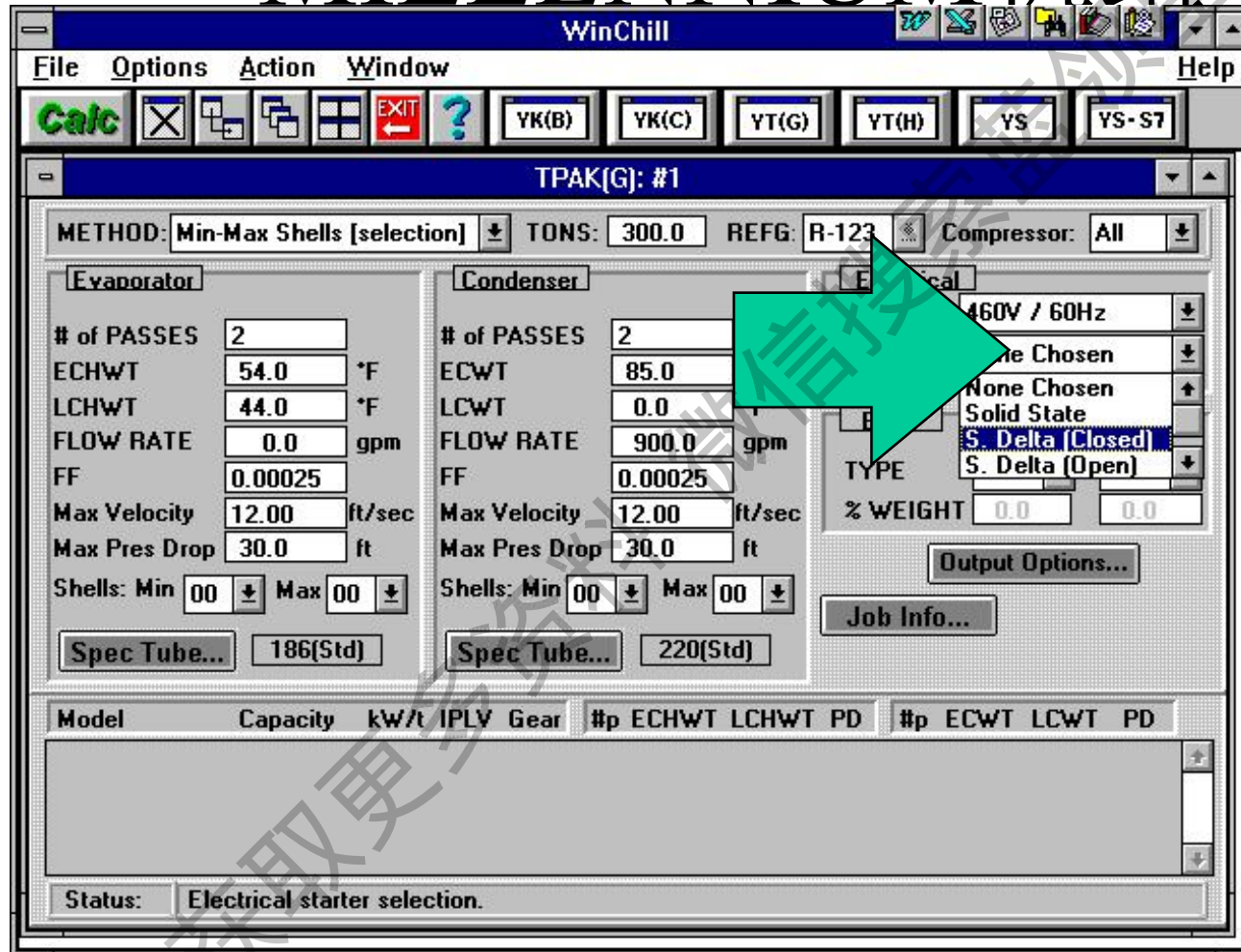

约克各办事处均可根据具体工程要求，由电脑选型，精确匹配各部件，为用户提供最高效率机组。





**U S A**



36USC380

*Proud Sponsor of the  
1996 U.S. Olympic Team*



约克空调连续三十六年服务奥运

# 售后服务



- 各地均驻有维修服务人员
- 人员经严格技术培训
- 提供产品的开机调试及维修保养工作
- 在HVAC行业具有丰富经验





 **YORK**<sup>®</sup>

*Makes the World*  
*A Very*  
**COOL**  
*Place*



约克带您进入凉爽世界