

中国第一重型机械集团公司标准

圆螺母

GB 812-88
代替 GB 812-76

材料: 45

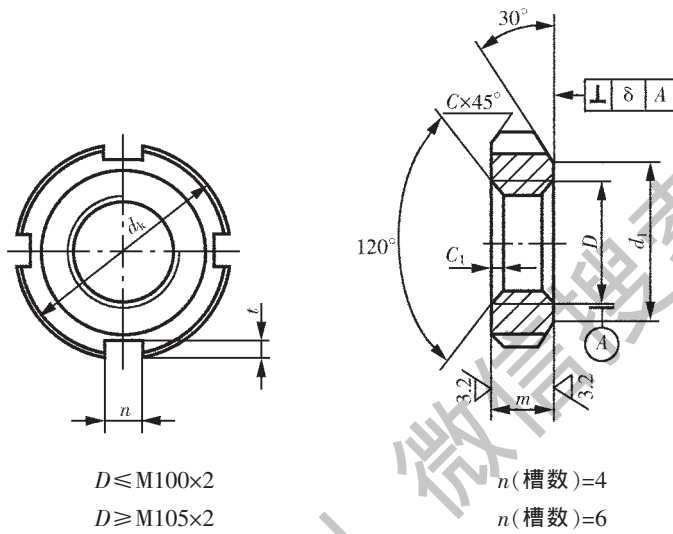

标记示例:

螺纹规格 $D=M16 \times 1.5$ 的圆螺母的标记为:

螺母 M16×1.5; 备注栏注: GB 812-88

mm

螺纹规格 $D \times P$	d_k	d_1	m	n		t		C	C_1	每 1000 个钢 螺母的重量 $kg \approx$
				max	min	max	min			
M16×1.5	30	22	8	5.30	5.00	3.10	2.50	0.5	0.5	27.0
M18×1.5	32	24								29.9
M20×1.5	35	27								35.6
M22×1.5	38	30								53.7
M24×1.5	42	34	10	6.30	6.00	3.60	3.00	1.0	0.5	67.0
M27×1.5	45	37								73.7
M30×1.5	48	40								80.4
M33×1.5	52	43								85.9
M36×1.5	55	46								96.3
M39×1.5	58	49								103.0
M42×1.5	62	53								117.2
M45×1.5	68	59	12	8.36	8.00	4.25	3.50	1.5	1.0	140.8
M48×1.5	72	61								184.8
M52×1.5	78	67								218.5
M56×2	85	74								267.8
M60×2	90	79								310.4
M64×2	95	84								341.6
M68×2	100	88								369.3
M72×2	105	93								509.4
M76×2	110	98	15	10.36	10.00	4.75	4.00	1.5	1.0	553.7
M80×2	115	103								599.6
M85×2	120	108								616.1
M90×2	125	112								786.5
M95×2	130	117	18	12.43	12.00	5.75	5.00	1.5	1.0	825.1
M100×2	135	122								845.2
M105×2	140	127								1099
M110×2	150	135								1295
M115×2	155	140	22	14.43	14.00	6.75	6.00	2.0	1.5	1363
M120×2	160	145								1403
M125×2	165	150								1457
M130×2	170	155								1511
M140×2	180	165	26	16.43	16.00	7.90	7.00	2.0	1.5	1924
M150×2	200	180								2585
M160×3	210	190								2793
M170×3	220	200								2953
M180×3	230	210	30	16.43	16.00	7.90	7.00	2.0	1.5	3615
M190×3	240	220								3801
M200×3	250	230								3986

注：①全部▲。

② 螺纹公差按 GB 197-81 规定的 6H 级。

③ 圆螺母的扳手槽或全部必须经过热处理，硬度 HRC 35~45。

④ 端面对螺纹轴心线的垂直度 (δ) 按 GB/T1184-1996 附录 B 表 B3 规定的 9 级公差。

⑤ 表面氧化或磷化处理。

⑥ 圆螺母用止动垫圈按 GB 858-88 选用。