

中国第一重型机械集团公司标准

扳手空间

JB/ZQ 4005-97
代替 JB/ZQ 4005-84

本标准根据 ISO 3318-1982《螺栓和螺母的装配工具—双头扳手，双头梅花扳手，两用扳手头部外形的最大尺寸》，ISO 2725-1973《机用和手用套筒扳手》和 GB 3228-82《机动套筒扳手的四方传动套筒》等规定的螺母扳手位置的尺寸而制订的。

扳手空间应符合图 1~图 8 和表的规定。

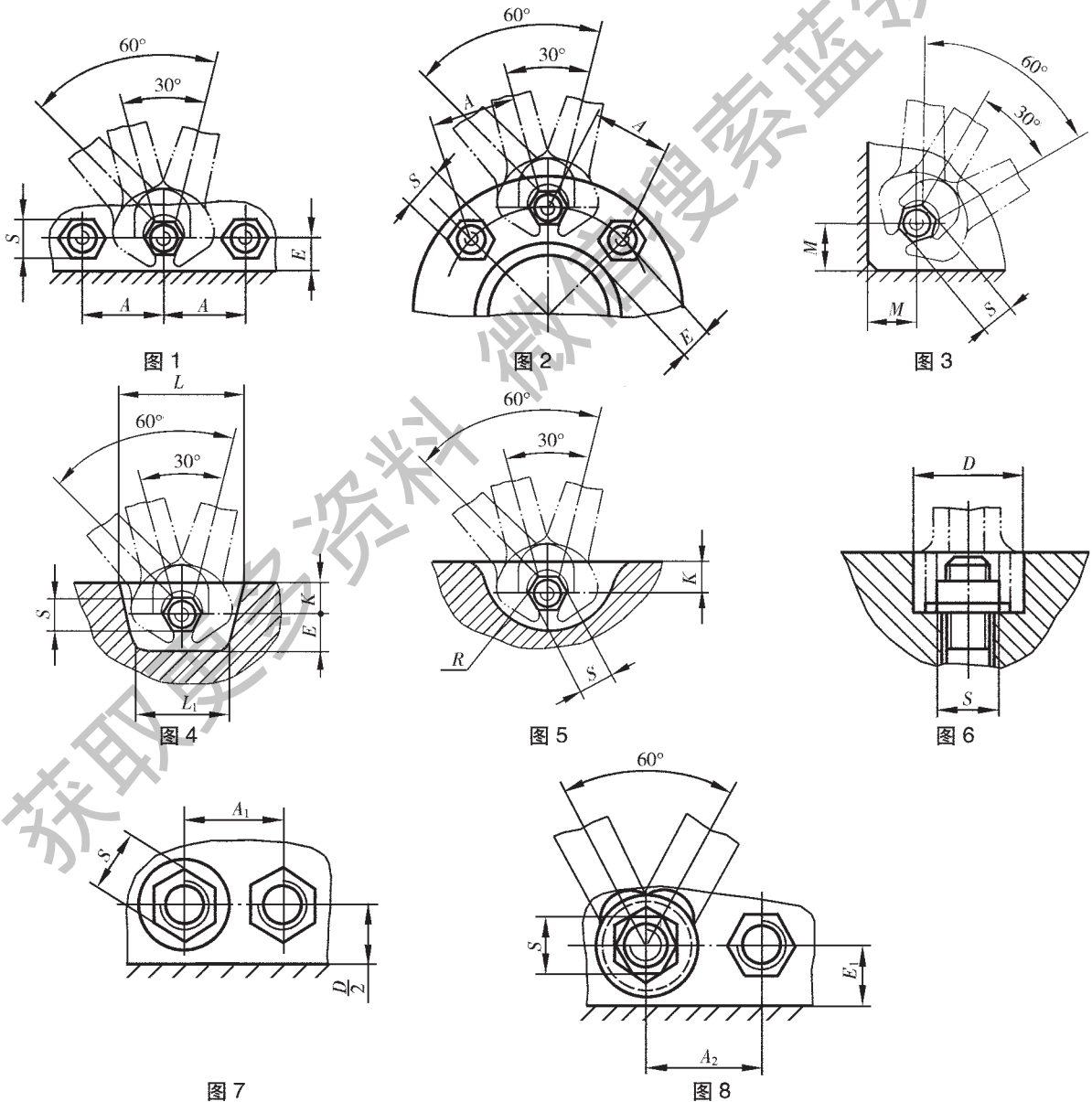

d	S	A	A_1	A_2	E	E_1	M	L	L_1	R	D
3	5.5	18	12	12	5	7	11	30	24	15	14
3.5	(6)	18	12	12	5	7	12	30	26	15	14
4	7	20	16	14	6	7	12	34	28	16	16
5	8	22	16	15	7	10	13	36	30	18	20
6	10	26	18	18	8	12	15	46	38	20	24
7	11	28	20	18	10	12	16	50	40	22	25
7	(12)	30	22	20	10	14	17	52	42	24	26
8	13	32	24	22	11	14	18	55	44	25	28
8	(14)	34	26	24	11	15	19	58	46	26	30
10	16	38	28	26	13	16	22	62	50	30	30
10	(17)	40	28	28	13	18	23	65	52	32	34
12	18	42	-	30	14	18	24	70	55	32	-
12	(19)	44	34	32	14	20	25	75	60	34	40
14	21	48	36	34	15	20	26	80	65	36	40
14	(22)	50	36	34	15	22	28	80	65	38	42
16	24	55	38	38	16	24	30	85	70	42	45
18	27	62	45	42	19	25	32	95	75	46	52
20	30	68	48	46	20	28	35	105	85	50	56
22	(32)	72	50	50	22	30	38	110	90	55	60
22	34	76	55	52	24	32	40	120	95	58	60
24	36	80	58	55	24	34	42	125	100	60	70
27	41	90	65	62	26	36	46	135	110	65	76
30	46	100	72	70	30	40	50	155	125	75	82
33	50	108	76	75	32	44	55	165	130	80	88
36	55	118	85	82	36	48	60	180	145	88	95
39	60	125	90	88	38	52	65	190	155	92	100
42	65	135	96	96	42	55	70	205	165	100	106
45	70	145	105	102	45	60	75	220	175	105	112
48	75	160	115	112	48	65	80	235	185	115	126
52	80	170	120	120	48	70	84	245	195	125	132
56	85	180	126	-	52	-	90	260	205	130	138
60	90	185	134	-	58	-	95	275	215	135	145
64	95	195	140	-	58	-	100	285	225	140	152
68	100	205	145	-	65	-	105	300	235	150	158
72	105	215	155	-	68	-	110	320	250	160	168
76	110	225	-	-	70	-	115	335	265	165	-
80	115	235	165	-	72	-	120	345	275	170	178
85	120	245	175	-	75	-	125	360	285	180	188
90	130	260	190	-	80	-	135	390	310	190	208
95	135	270	-	-	85	-	140	405	320	200	-
100	145	290	215	-	95	-	150	435	340	215	238
105	150	300	-	-	98	-	155	450	350	220	-
110	155	310	-	-	100	-	160	460	360	225	-
110	(160)	320	240	-	105	-	165	475	370	235	270
115	165	330	-	-	108	-	170	495	385	245	-
120	170	340	-	-	108	-	175	505	400	250	-
120	(175)	350	260	-	110	-	180	520	410	260	300
125	180	360	-	-	115	-	185	535	420	270	-
130	185	370	-	-	115	-	190	545	430	275	-
140	200	385	-	-	120	-	205	585	465	295	-
150	210	420	310	-	130	-	215	625	495	310	350
170	(240)	475	345	-	150	-	245	705	555	350	380

注：① K 值的大小等于 E 。

② 括号内的 S 尺寸，不推荐采用。

③ d 为螺纹直径。