

中国第一重型机械集团公司标准

# 内六角螺塞 (PN=31.5 MPa)

JB/ZQ 4444-97  
代替 JB/ZQ 4444-86

材料: 35

本标准作为设计资料, 供绘图时参考。

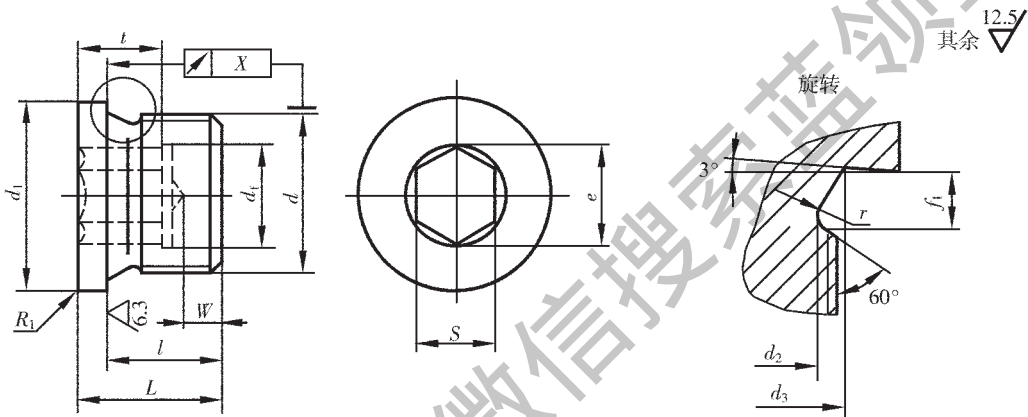

获取更多资料

微信搜索 全球领星球

mm

$d$			$d_1$	$d_2$	$d_3$	$e$	$l$	$L$	$S$	$t$	$w$	$f_1$	$X$	$r$	重量 (kg/1000件) ≈
米制螺纹		管螺纹	(h13)	0 -0.2	0 -0.3	≥	±0.2	≈	(D12)	≥	≥	+0.3 0			
M8×1	-	-	14	6.4	8.3	4.6	8	11	4	3.5	3	2			6.4
M10×1	-	G $\frac{1}{8}$ A	14	8.3	10	5.7	8	11	5	5	3	2			6.34
M12×1.5	-	-	17	9.7	12.3	6.9	12	15	6	7	3	3			11.3
-	-	G $\frac{1}{4}$ A	18	11.2	13.4	6.9	12	15	6	7	3	3			14.6
M14×1.5	-	-	19	11.7	14.3	6.9	12	15	6	7	3	3			16.0
M16×1.5	-	-	21	13.7	16.3	9.2	12	15	8	7.5	3	3			19.0
-	-	G $\frac{3}{8}$ A	22	14.7	17	9.2	12	15	8	7.5	3	3	0.1	1.5	21.4
M18×1.5	-	-	23	15.7	18.3	9.2	12	16	8	7.5	3	3			28.3
M20×1.5	-	-	25	17.7	20.3	11.4	14	18	10	7.5	4	3			37.5
-	-	G $\frac{1}{2}$ A	26	18.4	21.3	11.4	14	18	10	7.5	4	4			40.8
M22×1.5	-	-	27	19.7	22.3	11.4	14	18	10	7.5	4	3			47.5
M24×1.5	-	-	29	21.7	24.3	13.7	14	18	11	7.5	4	3			53.5
M26×1.5	-	-	31	23.7	26.3	13.7	16	20	11	9	4	3			68.7
-	M27×2	G $\frac{3}{4}$ A	32	23.9	27	13.7	16	20	11	9	4	4			73.5
M30×1.5	M30×2	-	36	27.7	30.3	19.4	16	20	16	9	4	4			84.0
-	M33×2	G1A	39	29.9	33.3	19.4	16	21	16	9	4	4			111
M36×1.5	M36×2	-	42	33	36.3	21.7	16	21	18	10.5	4	4			134
M38×1.5	-	G1 $\frac{1}{8}$ A	44	35	38.3	21.7	16	21	18	10.5	4	4			149
-	M39×2	-	46	36	39.3	21.7	16	21	18	10.5	4	4			163
M42×1.5	M42×2	G1 $\frac{1}{4}$ A	49	39	42.3	25.2	16	21	21	10.5	4	4	0.2	2	187
M45×1.5	M45×2	-	52	42	45.3	25.2	16	21	21	10.5	4	4			215
M48×1.5	M48×2	G1 $\frac{1}{2}$ A	55	45	48.1	27.4	16	21	24	10.5	4	4			246
M52×1.5	M52×2	-	60	49	52.3	27.4	16	21	24	10.5	4	4			302
-	-	G1 $\frac{3}{4}$ A	62	50.4	54	36.6	20	25	32	14	4	5			320
-	M56×2	-	64	53	56.3	36.6	20	25	32	14	4	4			386
-	M60×2	G2A	68	56.3	60.3	36.6	20	25	32	14	4	4			445
-	M64×2	-	72	61	64.3	36.6	20	25	32	14	4	4			530

注：①  $d_t$  尺寸由制造厂确定。

② 技术条件按 JB 1003-77 《焊接管接头，螺母、螺塞、垫圈技术条件》。