

中国第一重型机械集团公司标准

薄型平键 型式尺寸

GB 1567-79

1 圆头薄型平键 (A 型)、平头薄型平键 (B 型) 和单圆头薄型平键 (C 型) 的型式尺寸, 应符合本标准的规定。

本标准作为设计资料, 是绘制薄型平键施工图的依据。

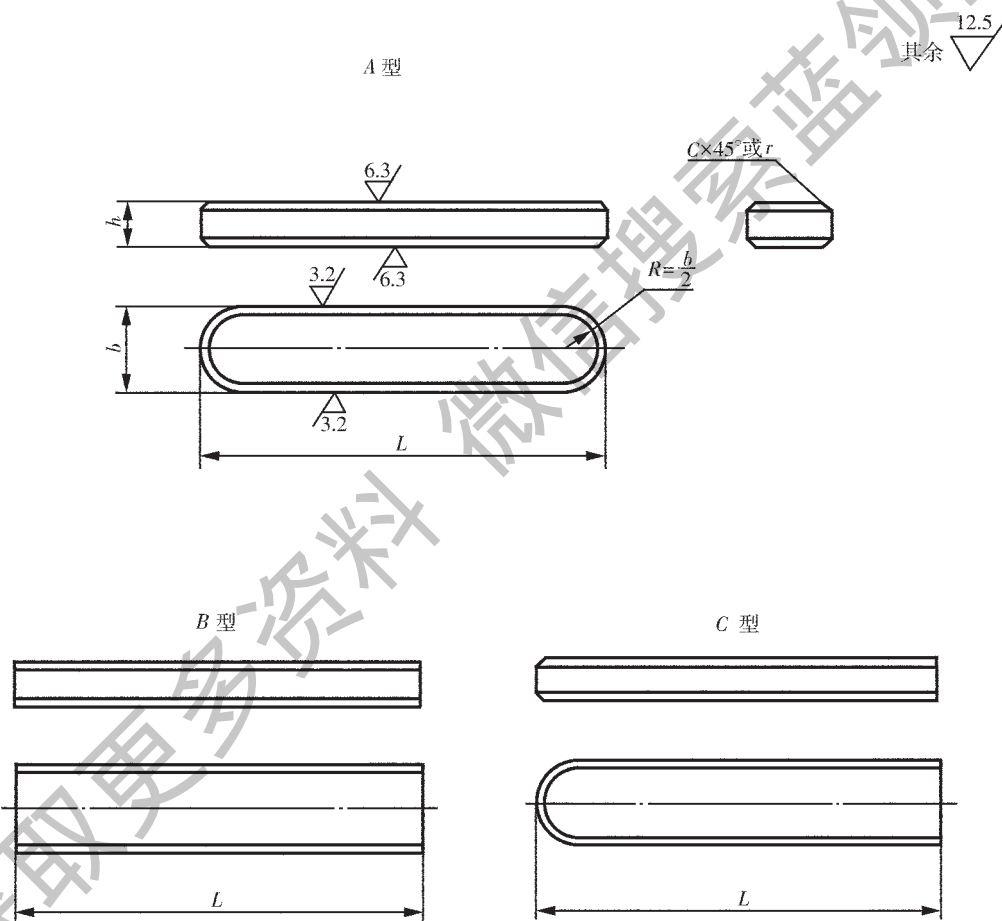

- 2 键槽的尺寸应符合 GB 1566-79 《薄型平键 键和键槽的剖面尺寸》的规定。
- 3 薄型平键的技术条件应符合 GB/T 1568-1997 《键 技术条件》的规定。
- 4 薄型平键的长度 L 及其公差推荐按 GB 1096-79 《普通平键》确定。

mm

b	公称尺寸	5	6	8	10	12	14	16	18	20	22	25	28	32	36
	极限偏差 (h9)	0 -0.030		0 -0.036		0 -0.043		0 -0.052		0 -0.062					
h	公称尺寸	3	4	5	6	6	6	7	7	8	9	9	10	11	12
	极限偏差 (h11)	0 -0.060		0 -0.075		0 -0.090		0 -0.110							
C 或 r		0.25~0.40			0.40~0.60				0.60~0.80				1.0 ~1.2		
L		平头薄型平键 (B 型) 每 1000 件的重量 kg≈													
公称尺寸	极限偏差 (h14)														
10	0 -0.36	1.17	-	-	-	-	-	-	-	-	-	-	-	-	-
12		1.41	-	-	-	-	-	-	-	-	-	-	-	-	-
14	0	1.64	2.63	-	-	-	-	-	-	-	-	-	-	-	-
16	-0.43	1.88	3.01	-	-	-	-	-	-	-	-	-	-	-	-
18		2.12	3.39	5.65	-	-	-	-	-	-	-	-	-	-	-
20		2.35	3.76	6.28	-	-	-	-	-	-	-	-	-	-	-
22	0	2.59	4.14	6.90	10.36	-	-	-	-	-	-	-	-	-	-
25	-0.52	2.94	4.71	7.85	11.78	-	-	-	-	-	-	-	-	-	-
28		3.30	5.28	8.79	13.19	15.83	-	-	-	-	-	-	-	-	-
32		3.77	6.03	10.05	15.07	18.09	-	-	-	-	-	-	-	-	-
36	0	4.24	6.78	11.3	17.0	20.3	23.7	-	-	-	-	-	-	-	-
40	-0.62	4.71	7.54	12.56	18.8	22.6	26.4	-	-	-	-	-	-	-	-
45		5.30	8.48	14.1	21.2	25.4	29.7	39.6	-	-	-	-	-	-	-
50		5.89	9.42	15.7	23.6	28.3	33.0	44.0	49.5	-	-	-	-	-	-
56	0	6.60	10.6	17.6	26.4	31.7	36.9	49.2	55.4	70.3	-	-	-	-	-
63	-0.74	-	11.9	19.8	29.7	35.7	41.5	55.4	62.3	79.1	98	-	-	-	-
70		-	13.2	22.0	33.0	39.6	46.2	61.5	69.2	87.9	109	123	-	-	-
80		-	-	25.1	37.7	45.2	52.8	70.3	79.1	100.5	124	141	176	-	-
90	0	-	-	28.3	42.4	50.9	59.3	79.1	89.0	113	140	159	198	249	-
100	-0.87	-	-	-	47.1	56.5	66.0	88.0	99.0	126	155	177	220	276	339
110		-	-	-	51.8	62.2	72.5	96.7	109	138	171	194	242	304	373
125		-	-	-	-	70.7	82.4	110	124	157	194	221	275	345	424
140	0	-	-	-	-	79.0	92.3	123	138	176	218	247	308	387	475
160	-1.0	-	-	-	-	-	106	141	158	201	248	283	352	442	543
180		-	-	-	-	-	-	158	178	226	280	318	396	497	610
200	0	-	-	-	-	-	-	-	198	251	311	353	440	553	678
220	-1.15	-	-	-	-	-	-	-	-	276	342	389	484	608	746
250		-	-	-	-	-	-	-	-	-	389	442	550	691	848
280	0 -1.30	-	-	-	-	-	-	-	-	-	-	495	615	774	950
320		-	-	-	-	-	-	-	-	-	-	-	703	884	1085
360	0	-	-	-	-	-	-	-	-	-	-	-	-	995	1221
400	-1.40	-	-	-	-	-	-	-	-	-	-	-	-	-	1356
对 A 型应减去的重量(kg) ≈		0.13	0.24	0.54	1.0	1.5	2.0	3.0	3.8	5.4	7.4	9.5	13	19	26
对 C 型应减去的重量(kg) ≈		0.07	0.12	0.27	0.5	0.75	1.0	1.5	1.9	2.7	3.7	4.8	6.5	9.5	13