

中国第一重型机械集团公司标准

无骨架防尘圈

JB/ZQ 4607-86
代替 Q/ZB 336-77

材料：橡胶 1-1、1-3、聚氨脂-1、3

本标准适用于活塞杆或阀杆等外露处防尘用的无骨架防尘圈。

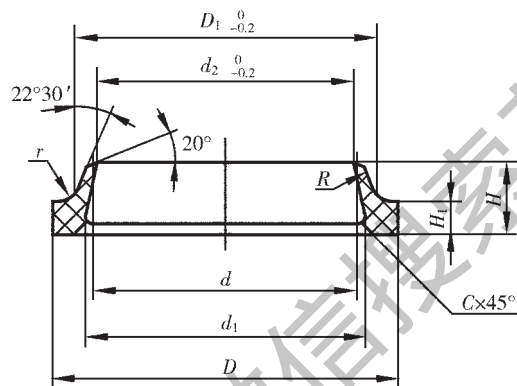

标记示例：

d=50 mm 的无骨架防尘圈，材料为聚氨脂-1；

防尘圈 50；材料栏注：聚氨脂-1；备注栏注：JB/ZQ 4607-86

mm

轴 径 <i>d</i>	<i>D</i>		<i>D</i> ₁	<i>d</i> ₁	<i>d</i> ₂	<i>H</i>	<i>H</i> ₁		<i>R</i>	<i>r</i>	<i>C</i>	每 1000 件重量 (kg)						
	公称尺寸	极限偏差					公称尺寸	极限偏差										
18	26	-0.14	22	19	17.2	5	2.5	±0.1	8	0.5	0.5	0.98						
20	28		24	21	19.2							1.07						
22	30		26	23	21.2							1.16						
25	33	29	26	24.2	1.30													
28	36	32	29	27.2	1.44													
30	38	34	31	29.2	1.53													
32	41	-0.17	36	33	30.9	6	3	±0.1	10	0.5	0.5	2.25						
35	44		39	36	33.9							2.43						
36	45		40	37	34.9							2.49						
40	49	44	41	38.9	2.74													
45	54	-0.20	49	46	43.9													3.05
		-0.60																

注：根据活塞杆直径和工作压力选择防尘圈材料。

续表

mm

轴 径 d	D		D_1	d_1	d_2	H	H_1		R	r	C	每 1000 件重量 (kg)
	公称尺寸	极限偏差					公称尺寸	极限偏差				
50	59	-0.20 -0.60	54	51	48.9	6	3	± 0.1	10	0.5	0.5	3.36
55	64		59	56	53.9							3.67
60	69		64	61	58.9							3.98
63	72		67	64	61.9							4.17
65	74		69	66	63.9							4.30
70	82	-0.23 -0.70	75	71	68.5	8	4	± 0.12	15	1	1	8.07
75	87		80	76	73.5							8.60
80	92		85	81	78.5							9.14
85	97		90	86	83.5							9.67
90	102		95	91	88.5							10.20
95	107		100	96	93.5							10.74
100	112		105	101	98.5							11.27
105	117		110	106	103.5							11.81
110	122		115	111	108.5							12.34
120	132		125	121	118.5							13.41
125	140	-0.26 -0.80	132	127	123	10	5	± 0.12	15	1	1	22.66
130	145		137	132	128							23.52
140	155		147	142	138							25.24
150	165		157	152	148							26.95
160	175		167	162	168							28.67
180	195	187	182	178	32.11							
200	218	-0.30 -0.90	208	202	197.5	12	6	± 0.15	15	2	1.5	52.10
220	238		228	222	217.5							57.00
250	268	-0.34 -1.00	258	252	247.5	12	6	± 0.15	15	2	1.5	64.61
280	298		288	282	277.5							72.12
320	338		328	322	317.5							82.12
360	378	-0.38 -1.10	368	362	357.5	12	6	± 0.15	15	2	1.5	92.13

注：全部▲。

附录 A

无骨架防尘圈用沟槽型式与尺寸

(补充件)

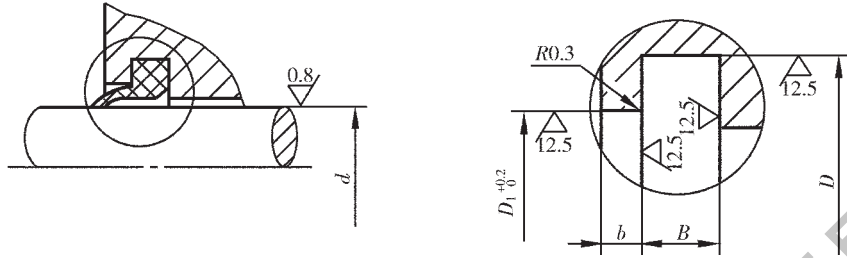

mm

轴径 <i>d</i>	<i>D</i>		<i>D</i> ₁	<i>B</i>		<i>b</i>	轴径 <i>d</i>	<i>D</i>		<i>D</i> ₁	<i>B</i>		<i>b</i>
	公称尺寸	极限偏差		公称尺寸	极限偏差			公称尺寸	极限偏差		公称尺寸	极限偏差	
18	26	+0.52 0	22	2.5	2	2	85	97	+0.87 0	90	4	3	
20	28		24				95	102		95			
22	30		26				100	107		100			
25	33	29	105				112	105					
28	36	32	110				117	110					
30	38	34	120				122	115					
32	41	+0.62 0	36	3	2.5	2.5	125	132	+1.00 0	125	5	+0.1 0	
35	44		39				130	140		132			
36	45		40				140	145		137			
40	49	44	150				155	147					
45	54	49	160				165	157					
50	59	54	180				175	167					
55	64	+0.74 0	59	4	3	3	180	195	+1.15 0	187	6	4	
60	69		64				200	218		208			
63	72		67				220	238		228			
65	74	69	250				268	258					
70	82	75	280				298	288					
75	87	80	320				338	328					
80	92	+0.87 0	85	4	3	3	360	378	+1.55 0	368	6	4	