

中国第一重型机械集团公司标准

热轧等边角钢

GB 9787-88
代替 YB 166-65

材料: Q235-A·F、Q235-A

符号意义

b —边宽度; I —惯性矩; d —边厚度; W —截面系数;
 r —内圆弧半径; i —惯性半径; r_1 —边端内圆弧半径; Z_0 —
重心距离。

边宽 $b=50$ mm, 边厚 $d=5$ mm, 长度 $L=4\ 000$ mm 热轧
等边角钢的标记示例:

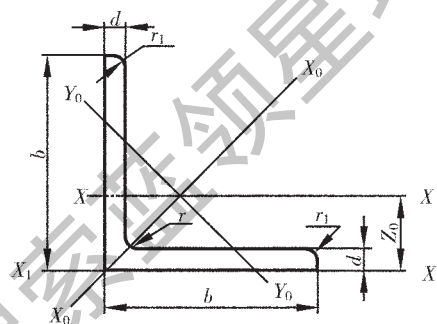
等边角钢 50×50×5, $L=4\ 000$ 

角钢 号数	尺寸(mm)			截面 面积 cm ²	理论 重量 kg/m	X-X			X ₀ -X ₀			Y ₀ -Y ₀			X ₁ -X ₁	Z ₀ cm	长度 m
	b	d	r			I _x cm ⁴	i _x cm	W _x cm ³	I _{x0} cm ⁴	i _{x0} cm	W _{x0} cm ³	I _{y0} cm ⁴	i _{y0} cm	W _{y0} cm ³	I _{x1} cm ⁴		
2	20	3	3.5	1.132	0.889	0.40	0.59	0.29	0.63	0.75	0.45	0.17	0.39	0.20	0.81	0.60	4 ~12
2.5	25	4	3.5	1.859	1.459	1.03	0.74	0.59	1.62	0.93	0.92	0.43	0.48	0.40	2.11	0.76	
3	30	4	4.5	2.276	1.786	1.84	0.90	0.87	2.92	1.13	1.37	0.77	0.58	0.62	3.63	0.89	
3.6	36	4	4.5	2.756	2.163	3.29	1.09	1.28	5.22	1.38	2.05	1.37	0.70	0.93	6.25	1.04	
4	40	4	5	3.086	2.422	4.60	1.22	1.60	7.29	1.54	2.58	1.91	0.79	1.19	8.56	1.13	
5	50	5	5.5	4.803	3.770	11.21	1.53	3.13	17.79	1.92	5.03	4.64	0.98	2.31	20.90	1.42	
5.6	56	5	6	5.415	4.251	16.02	1.72	3.97	25.42	2.17	6.42	6.61	1.10	2.98	29.33	1.57	
6.3	63	6	7	7.288	5.721	27.12	1.93	6.00	43.03	2.43	9.66	11.20	1.24	4.46	50.14	1.78	
7	70	7	8	9.424	7.398	43.09	2.14	8.59	68.35	2.69	13.81	17.82	1.38	6.34	80.29	1.99	
8	80	8	9	12.303	9.658	73.49	2.44	12.83	116.60	3.08	20.61	30.39	1.57	9.46	136.97	2.27	
9	90	10	10	17.167	13.476	128.58	2.74	20.07	203.90	3.45	32.04	53.26	1.76	14.52	244.07	2.59	
10	100	10	12	19.261	15.120	179.51	3.05	25.06	284.68	3.84	40.26	74.35	1.96	18.54	334.48	2.84	
10	100	14	12	26.256	20.611	236.53	3.00	33.73	374.06	3.77	52.90	99.00	1.94	23.44	470.75	2.99	
12.5	125	10	14	24.373	19.133	361.67	3.85	39.97	573.89	4.85	64.93	149.46	2.48	30.62	651.93	3.45	
12.5	125	14	14	38.367	26.193	481.65	3.80	54.16	763.73	4.78	86.41	199.57	2.45	39.13	915.61	3.61	
14	140	12	14	32.512	25.522	603.68	4.31	59.80	958.79	5.43	96.85	248.57	2.76	45.02	1099.28	3.90	
16	160	12	16	37.441	29.391	916.58	4.95	78.98	1455.68	6.24	128.67	377.49	3.18	60.74	1639.57	4.39	
18	180	18	16	61.955	48.634	1875.12	5.50	145.64	2988.24	6.94	234.78	762.01	3.51	105.14	3502.43	5.13	
20	200	18	18	69.301	54.401	2620.64	6.15	182.22	4164.54	7.75	294.48	1076.74	3.94	135.52	4808.13	5.62	
20	200	24	18	90.661	71.168	3338.25	6.07	236.17	5294.97	7.64	374.41	1381.53	3.90	166.55	6457.16	5.87	

注: 1) $r_1=d/3$, 表中 r 值不作验收依据。技术要求按 GB 9787 的规定。
2) 全部▲。